

Whirlpool®

FRENCH DOOR BOTTOM MOUNT REFRIGERATOR



USE & CARE GUIDE

WWW.WHIRLPOOL.COM
U.S.: 1-800-253-1301

WWW.WHIRLPOOL.CA
CANADA: 1-800-807-6777

TABLE OF CONTENTS

Congratulations on your purchase and welcome to the Whirlpool Brand family of high-quality appliances. Your new Whirlpool® French Door Refrigerator combines advanced cooling technology with simple operation and high efficiency.

Each appliance that leaves our factory is inspected thoroughly to ensure that it is working properly.

REFRIGERATOR SAFETY	3
Proper Disposal of Your Old Refrigerator.....	4
PARTS AND FEATURES	5
What's New Behind the Doors?.....	5
INSTALLATION INSTRUCTIONS	6
Unpack the Refrigerator.....	6
Location Requirements.....	7
Remove and Replace Refrigerator Doors.....	8
Remove and Replace Freezer Drawer Front	11
Electrical Requirements	12
Water Supply Requirements.....	12
Connect the Water Supply.....	12
Handle Installation and Removal	14
Refrigerator Leveling, Door Closing and Alignment	16
FILTERS AND ACCESSORIES	17
Water Filtration System.....	17
Install Air Filter (on some models).....	18
Install Produce Preserver (on some models).....	19
Accessories.....	20
REFRIGERATOR USE	21
Opening and Closing Doors.....	21
Using the Controls	21
Water and Ice Dispensers.....	24
Ice Maker and Ice Storage Bin (on some models)	25

Please read the Use and Care Instructions in this guide before operating your new refrigerator. Like all appliances, your refrigerator may require maintenance or repair from time to time, but you can help to ensure that your refrigerator provides many years of reliable service by following the instructions in this guide.

REFRIGERATOR FEATURES	27
Refrigerator Shelves.....	27
Crisper Drawers/Pantry Drawer/Crisper Cover	27
Crisper Humidity Control	28
Temperature-Controlled Drawer	28
Door Bins.....	29
Pizza Pocket and Drawer Divider	29
REFRIGERATOR CARE	30
Cleaning	30
Lights.....	31
Vacation and Moving Care.....	31
TROUBLESHOOTING	32
Operation.....	32
Noise	33
Temperature and Moisture.....	34
Ice and Water	35
Doors.....	37
PERFORMANCE DATA SHEETS	39
WARRANTY	40
SERVICE NUMBERS	BACK COVER

REFRIGERATOR SAFETY

Your safety and the safety of others are very important.

We have provided many important safety messages in this manual and on your appliance. Always read and obey all safety messages.



This is the safety alert symbol.

This symbol alerts you to potential hazards that can kill or hurt you and others.

All safety messages will follow the safety alert symbol and either the word “DANGER” or “WARNING.” These words mean:

⚠ DANGER

You can be killed or seriously injured if you don't immediately follow instructions.

⚠ WARNING

You can be killed or seriously injured if you don't follow instructions.

All safety messages will tell you what the potential hazard is, tell you how to reduce the chance of injury, and tell you what can happen if the instructions are not followed.

IMPORTANT SAFETY INSTRUCTIONS

WARNING: To reduce the risk of fire, electric shock, or injury when using your refrigerator, follow these basic precautions:

- Plug into a grounded (earthed) outlet.
- Do not remove ground prong.
- Do not use an adapter.
- Do not use an extension cord.
- Disconnect power before servicing.
- Replace all parts and panels before operating.
- Remove doors from your old refrigerator.
- Use nonflammable cleaner.
- Do not store or use petrol, flammable liquids or gas in the vicinity of this or other electrical appliances. The fumes can cause fires or explosions.
- Do not store explosive substances such as aerosol cans with a flammable propellant in this refrigerator.
- Do not use or place electrical devices inside the refrigerator compartments if they are not of the type expressly authorized by the manufacture.
- Use two or more people to move and install refrigerator.
- Disconnect power before installing ice maker (on ice maker kit ready models only).
- A qualified service technician must install the water line and ice maker.
- Connect to a potable water supply only.
- Use a sturdy glass when dispensing ice (on some models).
- This appliance is not intended for use by persons (including children) with reduced physical, sensory or mental capabilities, or lack of experience and knowledge, unless they have been given supervision or instruction concerning use of the appliance by a person responsible for their safety.
- Children should be supervised to ensure that they do not play with the appliance.
- To avoid the risk of children becoming trapped and suffocating, do not allow them to play or hide inside the refrigerator.
- If the power supply cord is damaged, it must be replaced by the manufacturer or its service agent or a similarly qualified person.

SAVE THESE INSTRUCTIONS

REFRIGERATOR SAFETY

Proper Disposal of Your Old Refrigerator

⚠️ WARNING

Suffocation Hazard

Remove doors from your old refrigerator.

Failure to do so can result in death or brain damage.

IMPORTANT: Child entrapment and suffocation are not problems of the past. Junked or abandoned refrigerators are still dangerous—even if they will sit for “just a few days.” If you are getting rid of your old refrigerator, please follow these instructions to help prevent accidents.

Before You Throw Away Your Old Refrigerator or Freezer:

- Take off the doors.
- Leave the shelves in place so that children may not easily climb inside.

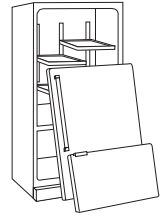

Important information to know about disposal of refrigerants:

Dispose of refrigerator in accordance with Federal and Local regulations. Refrigerants must be evacuated by a licensed, EPA certified refrigerant technician in accordance with established procedures.

PARTS AND FEATURES

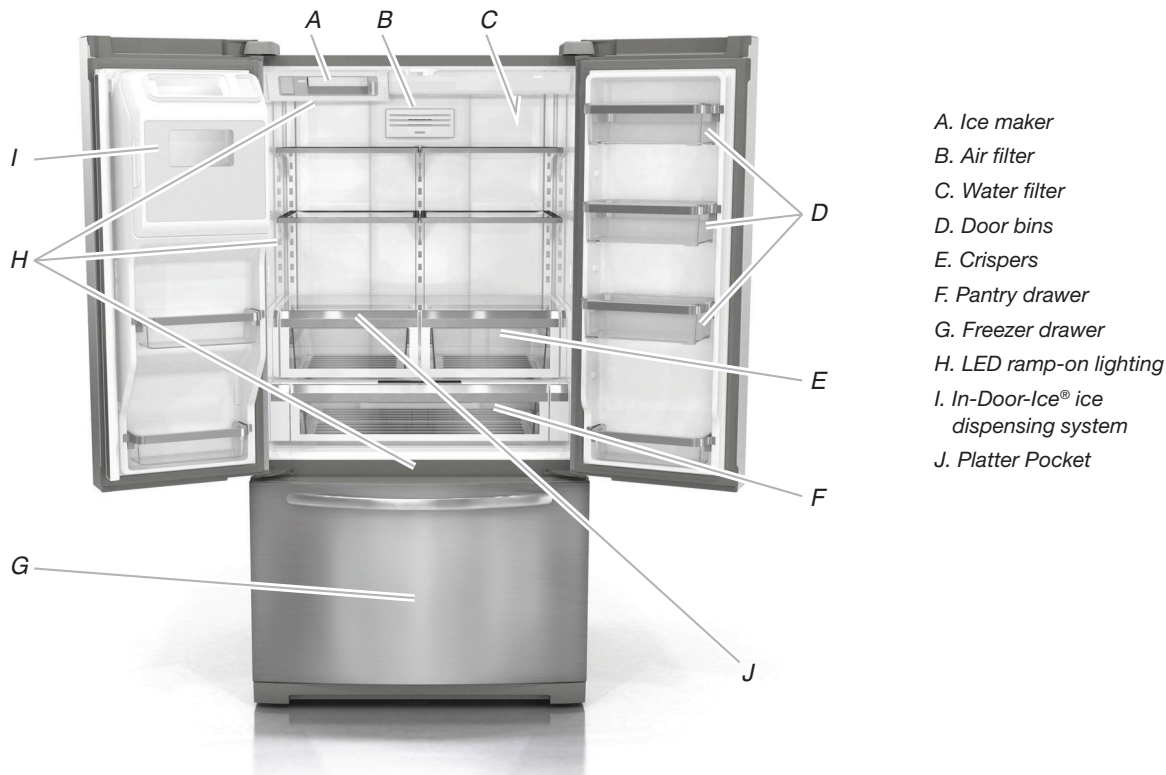

- A. Ice maker
- B. Air filter
- C. Water filter
- D. Door bins
- E. Crispers
- F. Pantry drawer
- G. Freezer drawer
- H. LED ramp-on lighting
- I. In-Door-Ice® ice dispensing system
- J. Platter Pocket

What's New Behind the Doors?

Your Whirlpool® French door refrigerator comes equipped with various innovative storage and energy-efficient features.

Energy and Normal Operating Sounds

Your new French Door Bottom Mount refrigerator has been designed to optimize energy efficiency, and better regulate temperatures to match cooling demand. You may notice that it operates differently from your previously owned refrigerator. It is normal for the high-efficiency compressor to run for extended periods of time at varying speeds in order to consume only the energy necessary for optimum efficiency. In addition, during various stages of the cooling cycle, you may hear normal operating sounds that are unfamiliar to you.

More Storage Space

The French Door Bottom Mount has the most fresh food storage space available, including a full-width, temperature controlled, pantry drawer perfect for storing veggie trays or party platters.

In-Door-Ice® Ice Dispensing System

The ice storage bin located in the door provides an entire extra shelf of storage space, and the storage bin is removable for easy access to filtered ice.

Dual Evaporator (on some models)

The refrigerator and freezer compartments have dedicated evaporators to provide fresh and frozen foods with separate climates. Frozen food stays cold and dry, while fresh food remains at the ideal temperature and humidity.

Platter Pocket

This full-width slide-out shelf tucked between the crispers and the lowest shelf is perfect for leftover family-sized casserole dishes, pizza boxes, and large party platters.

Water Filter

NSF® Certified filter reduces chlorine taste and odor, particulates (class I), lead, and mercury. Replacing the water filter every 6 months ensures clean, filtered drinking water.

Air Filter

An air filter is 15 times more powerful than baking soda at reducing common food odors inside the refrigerator.

Produce Preserver (on some models)

Ethylene is a natural gas produced by fruits and vegetables to promote ripening. The Produce Preserver absorbs ethylene, to delay the over-ripening of fresh produce. As a result, certain produce items will stay fresh longer.

CoolVox® Kitchen Sound System (on some models)

We made the kitchen pulse with energy by adding music where it's never been before. The CoolVox® kitchen sound system pairs easily with smart phones, tablets or other Bluetooth®† mobile devices.

Water Dispenser with Measured Fill (on some models)

The measured fill feature allows you to dispense the desired amount of filtered water.

†BLUETOOTH is a registered trademark of Bluetooth SIG, Inc.

INSTALLATION INSTRUCTIONS

LED Lighting

The LED lights do not ever need to be replaced.

MicroEdge® Glo Shelves (on some models)

Industry-exclusive MicroEdge® Glo shelves make every snack stand out in your refrigerator. By moving LED lighting to a new spot under the shelves, this leading-edge technology elevates the look and feel of your refrigerator.

Door Alarm

A helpful alarm sounds when the refrigerator door or freezer drawer is left ajar.

Power Outage Indicator

If the power should go out while you are away from home, this indicator will let you know the refrigerator has been without power.

Unpack the Refrigerator

WARNING

Excessive Weight Hazard

Use two or more people to move and install refrigerator.

Failure to do so can result in back or other injury.

When Moving Your Refrigerator:

Your refrigerator is heavy. When moving the refrigerator for cleaning or service, be sure to cover the floor with cardboard or hardboard to avoid floor damage. Always pull the refrigerator straight out when moving it. Do not wiggle or “walk” the refrigerator when trying to move it, as floor damage could occur.

Remove the Packaging

- Remove tape and glue residue from surfaces before turning on the refrigerator. Rub a small amount of liquid dish soap over the adhesive with your fingers. Wipe with warm water and dry.
- Do not use sharp instruments, rubbing alcohol, flammable fluids, or abrasive cleaners to remove tape or glue. These products can damage the surface of your refrigerator. For more information, see “Refrigerator Safety.”
- Dispose of/recycle all packaging materials.

Clean Before Using

After you remove all of the packaging materials, clean the inside of your refrigerator before using it. See the cleaning instructions in “Refrigerator Care.”

Important information to know about glass shelves and covers:

Do not clean glass shelves or covers with warm water when they are cold. Shelves and covers may break if exposed to sudden temperature changes or impact, such as bumping. Tempered glass is designed to shatter into many small, pebble-size pieces. This is normal. Glass shelves and covers are heavy. Use both hands when removing them to avoid dropping.

INSTALLATION INSTRUCTIONS

Location Requirements

⚠ WARNING



Explosion Hazard

Keep flammable materials and vapors, such as gasoline, away from refrigerator.

Failure to do so can result in death, explosion, or fire.

IMPORTANT: This appliance is intended to be used in household and similar applications such as:

- Staff kitchen areas in shops, offices and other working environments;
- Farm houses and by clients in hotels, motels and other residential type environments;
- Bed and breakfast type environments;
- Catering and similar non-retail applications.

To ensure proper ventilation for your refrigerator, allow for a minimum 1/2" (1.25 cm) of space on each side and at the top. Allow for a minimum 1" (2.54 cm) space behind the refrigerator. If your refrigerator has an ice maker, allow extra space at the back for the water line connections. When installing your refrigerator next to a fixed wall, leave a 3 3/4" (9.5 cm) minimum space between the refrigerator and wall to allow the door to swing open.

NOTE: This refrigerator is intended for use in a location where the temperature ranges from a minimum of 55°F (13°C) to a maximum of 110°F (43°C). The preferred room temperature range for optimum performance, which reduces electricity usage and provides superior cooling, is between 60°F (15°C) and 90°F (32°C). It is recommended that you do not install the refrigerator near a heat source such as an oven or radiator.

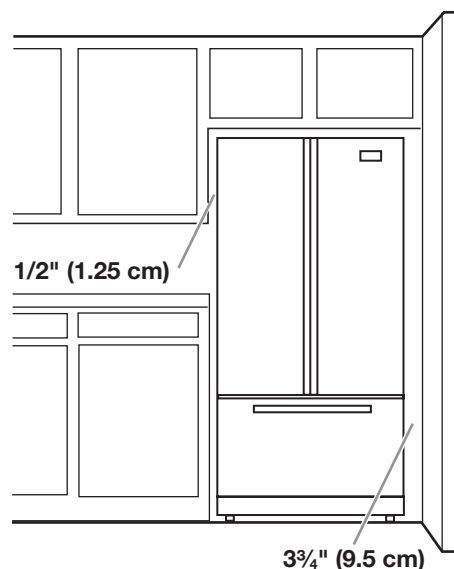

INSTALLATION INSTRUCTIONS

Remove and Replace Refrigerator Doors

NOTE: Measure the width of your door opening, to see whether or not you need to remove the refrigerator doors to move the refrigerator into your home. If door removal is necessary, see the following instructions.

IMPORTANT: If the refrigerator was previously installed and you are moving it out of the home, before you begin, turn the refrigerator control OFF. Unplug the refrigerator or disconnect power. Remove food and adjustable door or utility bins from doors.

Gather the required tools and read all instructions before removing doors.

TOOLS NEEDED: 3/16" hex key wrench and a #2 Phillips screwdriver



WARNING

Electrical Shock Hazard

Disconnect power before removing doors.

Failure to do so can result in death or electrical shock.

Door Removal and Replacement

**Style 1 – Water Dispenser
Tubing Connection**

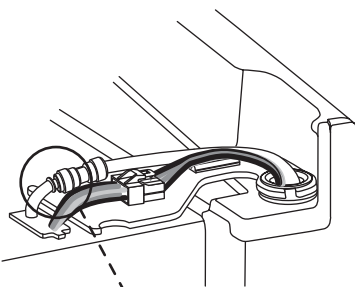

A. Outer Ring

**Style 2 – Water Dispenser
Tubing Connection**

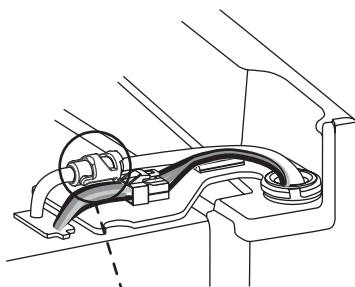

A. Outer Ring

Wiring Plug

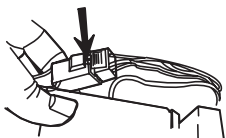

Top Left Hinge

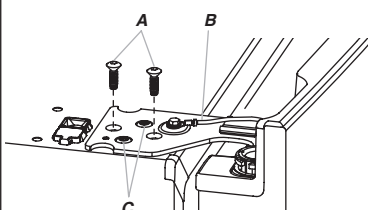

A. 3/16" Internal Hex-Head Screws
B. Ground Wire (Do Not Remove)
C. Do Not Remove Screws

Top Right Hinge

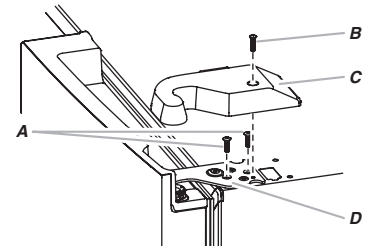

A. 3/16" Internal Hex-Head Screws
B. Hinge Cover Screw
C. Top Hinge Cover
D. Top Hinge

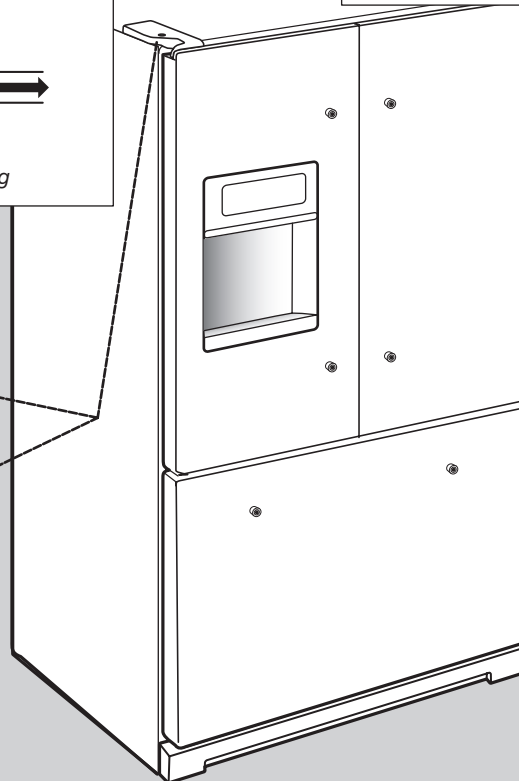

INSTALLATION INSTRUCTIONS

Remove Right-Hand Refrigerator Door

⚠ WARNING



Electrical Shock Hazard

Disconnect power before removing doors.

Failure to do so can result in death or electrical shock.

1. Unplug refrigerator or disconnect power.
2. Keep the refrigerator doors closed until you are ready to lift them free from the cabinet.
NOTE: Provide additional support for the refrigerator door while the hinges are being removed. Do not depend on the door gasket magnets to hold the door in place while you are working.
3. Using a Phillips screwdriver, remove the cover from the Top Hinge.
4. Using the 3/16" hex key wrench, remove the two internal hex head screws from the top hinge, and set aside.
NOTE: Do not remove the two locator screws. These screws will help you align the hinge when you replace the door.

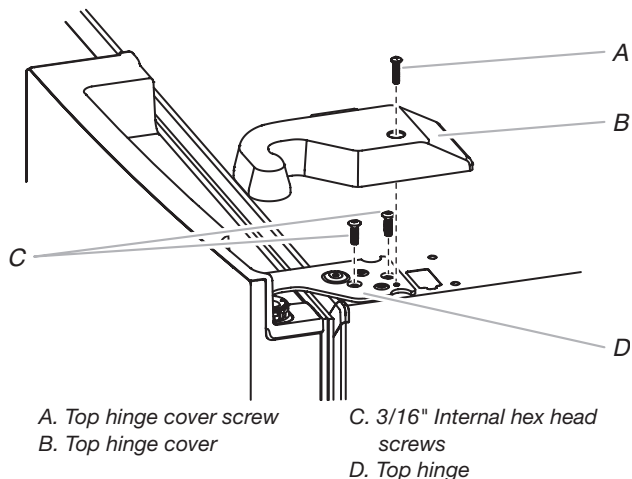

Remove Left-Hand Refrigerator Door

IMPORTANT: The tubing and wiring for the water dispenser run through the left-hand door hinge, so they must be disconnected before removing the door.

1. Using a Phillips screwdriver, remove the cover from the top hinge.

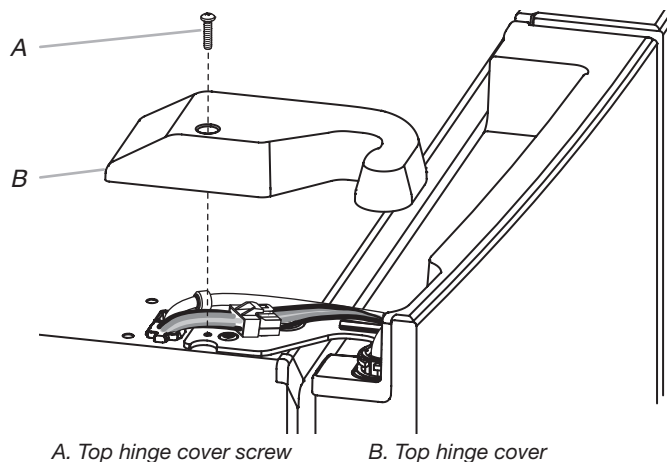

2. Disconnect the water dispenser tubing located on top of the door hinge.

Style 1 - Press the outer ring against the face of the fitting and gently pull the dispenser tubing free.

NOTE: The water dispenser tubing remains attached to the left-hand refrigerator door.

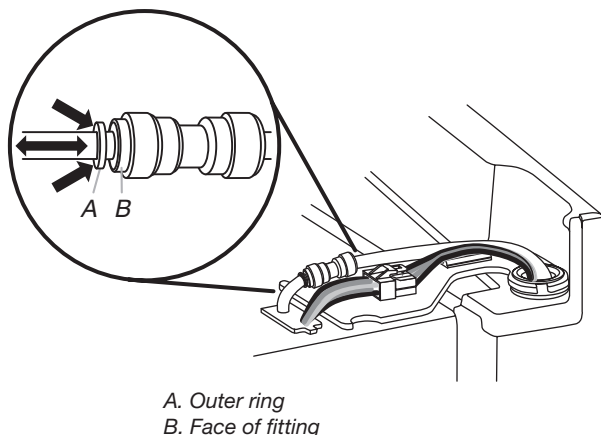

⚠ WARNING

Excessive Weight Hazard

Use two or more people to lift the refrigerator door.

Failure to do so can result in back or other injury.

5. Lift the refrigerator door from the bottom hinge pin. The top hinge will come away with the door.

INSTALLATION INSTRUCTIONS

Style 2 - Firmly pull up on the clasp. Then, pull the tubing out of the fitting.

NOTE: The water dispenser tubing remains attached to the left-hand refrigerator door.

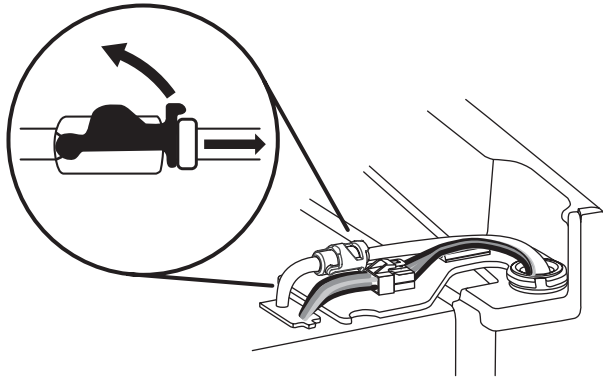

3. Disconnect the wiring plug located on top of the door hinge.

- Grasp each side of the wiring plug. With your left thumb, press down to release the catch and pull the sections of the plug apart.

NOTE: Do not remove the green, ground wire. It should remain attached to the door hinge.

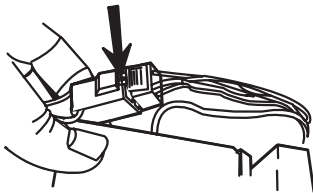

4. Using the 3/16" hex key wrench, remove the two internal hex head screws from the top hinge, and set aside.

NOTES:

- Provide additional support for the refrigerator door while the hinges are being removed. Do not depend on the door gasket magnets to hold the door in place while you are working.
- Do not remove the two locator screws. These screws will help you align the hinge when you replace the door.

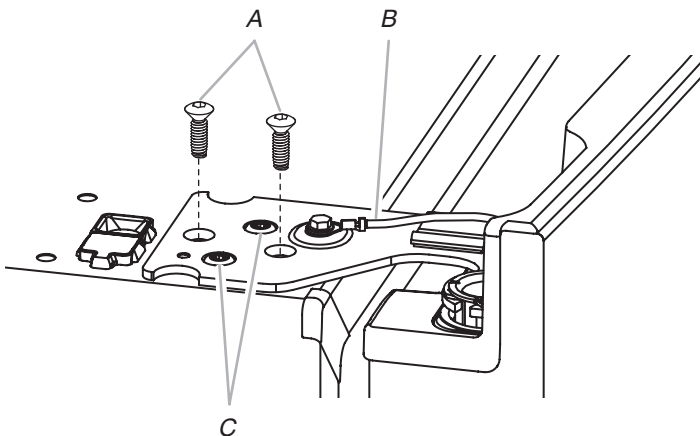

A. 3/16" Internal hex head screws

B. Ground wire (do not remove)

C. Locator screws (do not remove)

5. Lift the refrigerator door from the bottom hinge pin. The top hinge will come away with the door.

NOTE: It may not be necessary to remove the bottom hinges and brake feet assemblies to move the refrigerator through a doorway.

- Only if necessary, use a driver with a #2 square bit tip to remove the bottom hinges and a 3/8" nut driver to remove the brake feet screws.

Replace Right-Hand Refrigerator Door

1. Set the right-hand door onto the bottom hinge pin.
2. Insert the top hinge pin into the open hole in the top of the refrigerator door.
3. Using the two 3/16" internal hex head screws, fasten the hinge to the cabinet. Do not tighten the screws completely.

Replace Left-Hand Refrigerator Door

IMPORTANT: Do not intertwine the water tubing and wiring bundles when reconnecting them.

1. Set the left-hand door onto the bottom hinge pin.
2. Using the two 3/16" internal hex head screws, fasten the hinge to the cabinet. Do not tighten the screws completely.

3. Reconnect the water dispenser tubing.

Style 1 - Insert the tubing into the fitting until it stops and the outer ring is touching the face of fitting.

Style 2 - Insert the tubing firmly into the fitting until it stops. Close the clasp around the tubing. The clasp snaps into place between the fitting and the collar.

4. Reconnect the electrical wiring.

- Push together the two sections of the wiring plug.

Final Steps

1. Completely tighten the four internal hex head screws (two on the right-hand door hinge and two on the left-hand door hinge).
2. Replace both top hinge covers.

INSTALLATION INSTRUCTIONS

Remove and Replace Freezer Drawer Front

Depending on the width of your door opening, it may be necessary to remove the freezer drawer front to move the refrigerator into your home.

IMPORTANT:

- If the refrigerator was previously installed and you are moving it out of the home, before you begin, turn the refrigerator control OFF, and unplug the refrigerator or disconnect power. Remove food from the freezer drawer.
- Two people may be required to remove and replace the freezer drawer front.

Tool Needed: 1/4" hex driver

Remove Drawer Front

1. Open the freezer drawer to its full extension.
2. Remove the two screws at the top, inside the drawer front (one on the left-hand side and one on the right-hand side) that fasten the drawer front to the drawer glides.
3. Lift up on the drawer front to release the plastic studs from the drawer glide bracket slots.

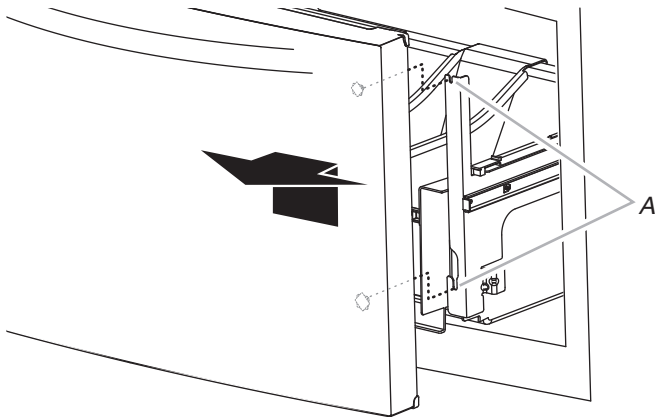

A. Drawer glide bracket slots

4. Slide the drawer glides back into the freezer.

Replace Drawer Front

1. Pull out the freezer drawer glides to their full extension.
2. Holding the drawer front by its sides, align the two plastic studs, located at the bottom, inside the drawer front, with the drawer glide bracket slots.

NOTE: It helps if one person holds the drawer glides steady while another person aligns the drawer front and inserts the studs into the slots.

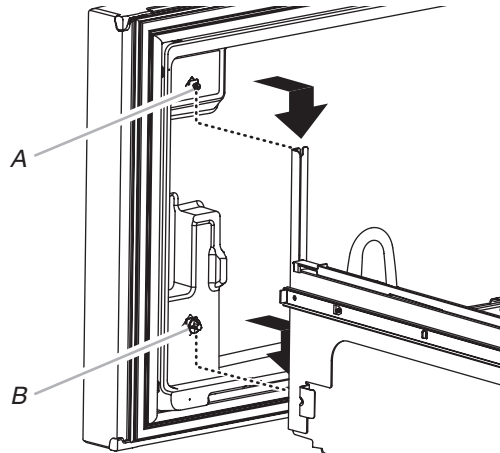

A. Drawer front screw
B. Drawer front plastic stud

3. Replace and tighten the two screws at the top of the drawer front (one on the left-hand side and one on the right-hand side).

Final Steps

⚠ WARNING



Electrical Shock Hazard

Plug into a grounded 3 prong outlet.

Do not remove ground prong.

Do not use an adapter.

Do not use an extension cord.

Failure to follow these instructions can result in death, fire, or electrical shock.

1. Plug into a grounded 3 prong outlet.
2. Reset the controls. See "Using the Control(s)."
3. Return all removable door parts to doors and the food to refrigerator.

INSTALLATION INSTRUCTIONS

Electrical Requirements

⚠ WARNING



Electrical Shock Hazard

Plug into a grounded 3 prong outlet.

Do not remove ground prong.

Do not use an adapter.

Do not use an extension cord.

Failure to follow these instructions can result in death, fire, or electrical shock.

Recommended Grounding Method

A 115 V, 60 Hz, AC only 15 or 20 A fused, grounded electrical supply is required. It is recommended that a separate circuit serving only your refrigerator and approved accessories be provided. Use an outlet that cannot be turned off by a switch. Do not use an extension cord.

NOTE: Before performing any type of installation, cleaning, or removing a light bulb, turn OFF Cooling, and then disconnect the refrigerator from the electrical source. When you have finished, reconnect the refrigerator to the electrical source and turn ON Cooling. See “Using the Control(s)” Section.

Before you move your refrigerator into its final location, it is important to make sure you have the proper electrical connection

Water Supply Requirements

A cold water supply with water pressure between 35 and 120 psi (241 and 827 kPa) is required to operate the water dispenser and ice maker. If you have questions about your water pressure, call a licensed, qualified plumber.

NOTE: If the water pressure is less than what is required, the flow of water from the water dispenser could decrease or ice cubes could be hollow or irregular shaped.

Reverse Osmosis Water Supply

IMPORTANT: The pressure of the water supply coming out of a reverse osmosis system and supplying the water inlet valve of the refrigerator needs to be between 35 and 120 psi (241 and 827 kPa).

If a reverse osmosis water filtration system is connected to your home cold water supply, the water pressure to the reverse osmosis system needs to be a minimum of 40 to 60 psi (276 to 414 kPa).

- Check to see whether the sediment filter in the reverse osmosis system is blocked. Replace the filter if necessary.
- Allow the storage tank on the reverse osmosis system to refill after heavy use. The tank capacity could be too small to keep up with the requirements of the refrigerator.

NOTE: Faucet-mounted reverse osmosis systems are not recommended.

- If your refrigerator has a water filter, it may further reduce the water pressure when used in conjunction with a reverse osmosis system. Remove the water filter. See the “Water Filtration System” section.

If you have questions about your water pressure, call a licensed, qualified plumber.

Connect the Water Supply

Read all directions before you begin.

IMPORTANT:

- **Connect to potable water supply only.**

Do not use with water that is microbiologically unsafe or of unknown quality without adequate disinfection before or after the system. Systems certified for cyst reduction may be used on disinfected waters that may contain filterable cysts.

- Plumbing must be installed in accordance with the International Plumbing Code and any local codes and ordinances.
- The gray water tubing on the back of the refrigerator (which is used to connect to the household water line) is a PEX (cross-linked polyethylene) tube. Copper and PEX tubing connections from the household water line to the refrigerator are acceptable, and will help avoid off-taste or odor in your ice or water. Check for leaks.

INSTALLATION INSTRUCTIONS

If PEX tubing is used instead of copper, we recommend the following part numbers:
W10505928RP (7 ft [2.14 m] jacketed PEX),
8212547RP (5 ft [1.52 m] PEX), or
W10267701RP (25 ft [7.62 m] PEX).

- Install tubing only in areas where temperatures will remain above freezing.

Tools Needed:

Gather the required tools and parts before starting installation.

- Flat-blade screwdriver
- 7/16" and 1/2" open-end wrenches or 2 adjustable wrenches
- 1/4" nut driver

NOTE: Do not use a piercing-type or 3/16" (4.76 mm) saddle valve, which reduces water flow and clogs easier.

Connect to Water Line

IMPORTANT: If you have turned the refrigerator on before the water was connected, turn OFF the ice maker.

1. Unplug refrigerator or disconnect power.
2. Turn OFF main water supply. Turn ON nearest faucet long enough to reduce water pressure in the water line.
3. Use a quarter-turn shut-off valve or the equivalent, served by a 1/2" (12.7 mm) household supply line.

NOTE: To allow sufficient water flow to the refrigerator, a minimum 1/2" (12.7 mm) size household supply line is recommended.

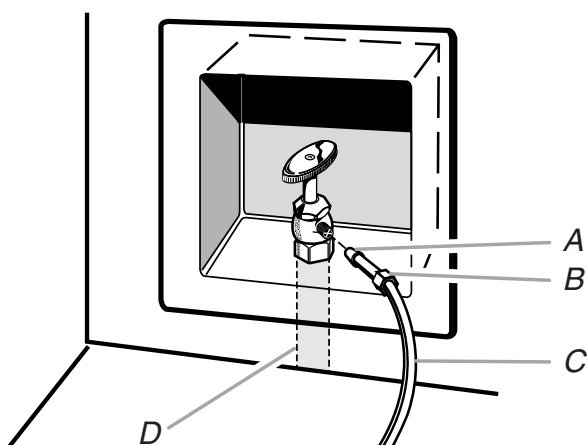

A. Sleeve C. Copper tubing (to refrigerator)
B. Nut D. Household supply line (1/2" [12.7 mm] minimum)

4. Now you are ready to connect the copper tubing to the shut-off valve. Use 1/4" (6.35 mm) O.D. (outside diameter) soft copper tubing to connect the shut-off valve and the refrigerator.

- Ensure that you have the proper length needed for the job. Be sure both ends of the copper tubing are cut square.
- Slip compression sleeve and compression nut onto copper tubing as shown. Insert end of tubing into outlet end squarely as far as it will go. Screw compression nut onto outlet end with adjustable wrench. Do not overtighten.

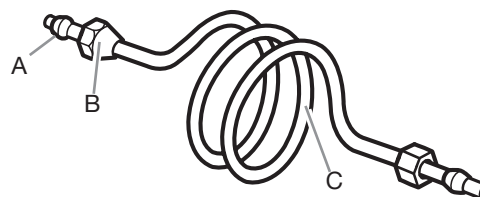

A. Compression sleeve C. Copper tubing
B. Compression nut

5. Place the free end of the tubing into a container or sink and turn on main water supply to flush out tubing until water is clear. Turn off shut-off valve on the water pipe.
NOTE: Always drain the water line before making the final connection to the inlet of the water valve to avoid possible water valve malfunction.
6. Bend the copper tubing to meet the water line inlet, located on the back of the refrigerator cabinet as shown. Leave a coil of copper tubing to allow the refrigerator to be pulled out of the cabinet or away from the wall for service.

Connect to Refrigerator

Follow the connection instructions specific to your model.

Style 1

1. Remove plastic cap from water valve inlet port. Attach the copper tubing to the valve inlet using a compression nut and sleeve as shown. Tighten the compression nut. Do not overtighten. Confirm copper tubing is secure by pulling on copper tubing.
2. Create a service loop with the copper tubing. Avoid kinks when coiling the copper tubing. Secure copper tubing to refrigerator cabinet with a "P" clamp.

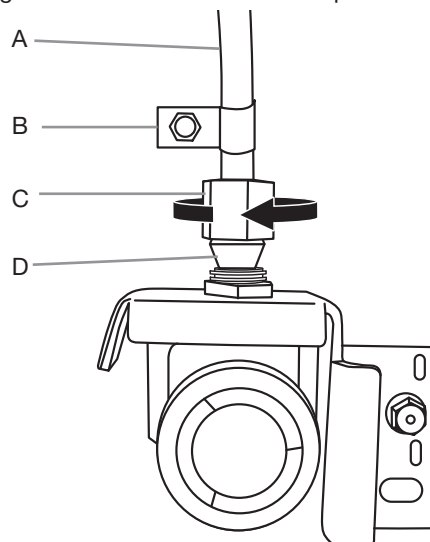

A. Copper tubing C. Compression nut
B. "P" clamp D. Compression sleeve

INSTALLATION INSTRUCTIONS

3. Turn on water supply to refrigerator and check for leaks. Correct any leaks.

Style 2

1. Unplug refrigerator or disconnect power.
2. Remove and discard the short, black plastic part from the end of the water line inlet.
3. Thread the nut onto the end of the tubing. Tighten the nut by hand. Then tighten it with a wrench two more turns. Do not overtighten.

NOTE: To avoid rattling, be sure the copper tubing does not touch the cabinet's side wall or other parts inside the cabinet.

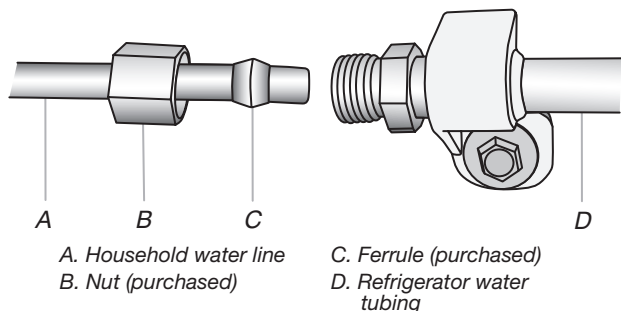

4. Install the water supply tube clamp around the water supply line to reduce strain on the coupling.
5. Turn ON shutoff valve.
6. Check for leaks. Tighten any connections (including connections at the valve) or nuts that leak.
7. On some models, the ice maker is equipped with a built-in water strainer. If your water conditions require a second water strainer, install it in the 1/4" (6.35 mm) water line at either tube connection. Obtain a water strainer from your appliance dealer.

Handle Installation and Removal

Parts Included: Door handles (2), Drawer handle(s) (1 or 2 depending on model), 1/8" hex key, spare setscrew(s)

NOTE: With the handles laying on a flat surface, the handles intended for the drawers are more curved. They will not mount flush against the doors.

Install Handles

NOTE: Handle mounting setscrews are preinstalled inside the handle.

1. Remove the handles from the packaging inside the refrigerator and place them on a soft surface.

Complete the Installation

⚠ WARNING



Electrical Shock Hazard

Plug into a grounded 3 prong outlet.

Do not remove ground prong.

Do not use an adapter.

Do not use an extension cord.

Failure to follow these instructions can result in death, fire, or electrical shock.

1. Plug into a grounded 3 prong outlet.
2. Flush the water system. See the "Water and Ice Dispensers" section.

NOTE: Allow 24 hours to produce the first batch of ice. Discard the first 3 batches of ice produced. Allow 3 days to completely fill the ice storage bin

2. Open a refrigerator compartment door. On the closed door, place a handle onto the shoulder screws so that the setscrews are facing the adjacent door.

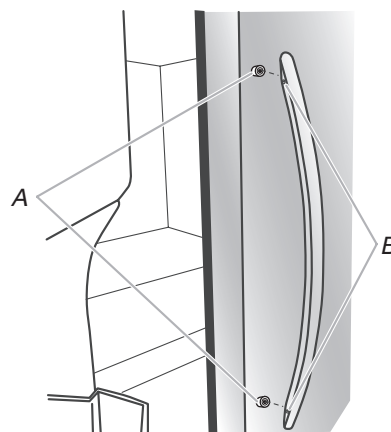

A. Shoulder screws
B. Setscrews inside the handle

3. Firmly push the handle toward the door until the handle base is flush against the door.

INSTALLATION INSTRUCTIONS

4. While holding the handle, insert the short end of the hex key into the upper hole and slightly rotate the hex key until it is engaged in the setscrew.

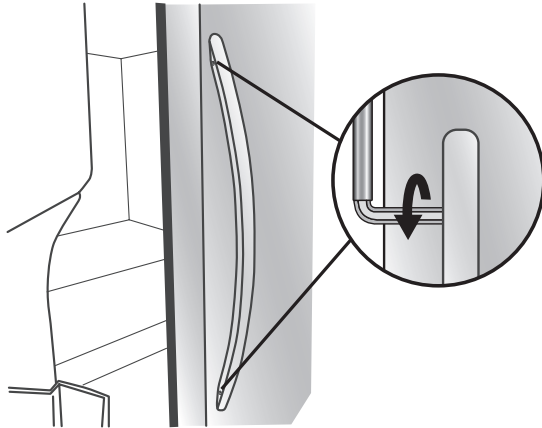

5. Using a clockwise motion tighten the setscrew just until it begins to contact the shoulder screw. Do not fully tighten.
6. Repeat steps 4 and 5 to fasten the lower setscrew.
7. Once both setscrews have been partially tightened as instructed in the previous steps, fully tighten both setscrews.

IMPORTANT: When the screws feel tight, tighten them an additional quarter-turn. The handle is not properly installed without this extra tightening.

8. Repeat steps 2 through 7 to install the other handle onto the adjacent refrigerator door.
9. With the drawer(s) closed, place the handle onto the shoulder screws so that the setscrews are facing down toward the floor.

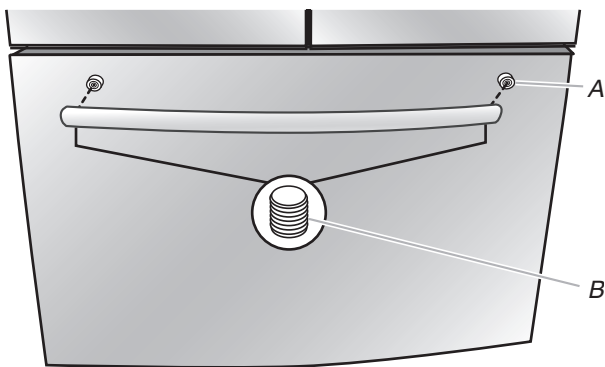

A. Shoulder screws
B. Setscrews inside the handle

10. Firmly push the handle toward the drawer until the handle base is flush against the drawer.
11. Insert the short end of the hex key into the left-hand hole and slightly rotate the hex key until it is engaged in the setscrew.



12. Using a left to right motion tighten the setscrew a quarter-turn at a time just until it begins to contact the shoulder screw. Do not fully tighten.
13. Repeat steps 11 and 12 to fasten the right-hand setscrew to the shoulder screw.
14. Once both setscrews have been partially tightened as instructed in the previous steps, fully tighten both setscrews.

IMPORTANT: When the screws feel tight, tighten them an additional quarter-turn. The handle is not properly installed without this extra tightening.

15. For some models, repeat steps 9 through 14 to install a handle on the second drawer.
16. Save the hex key and all instructions.

Remove the Handles

1. While holding the handle, insert the short end of the hex key into a setscrew hole and slightly rotate the hex key until it is engaged in the setscrew.
2. Using a right to left motion loosen the setscrew a quarter-turn at a time.
3. Repeat steps 1 and 2 for the other setscrew. Slowly pull the handle away from the door or drawer.
4. If necessary, use a Phillips screwdriver to remove the shoulder screws from the door.

INSTALLATION INSTRUCTIONS

Refrigerator Leveling, Door Closing and Alignment

The base grille covers the adjustable brake feet and roller assemblies located at the bottom of the refrigerator below the freezer drawer. Before making any adjustments, remove the base grille and move the refrigerator to its final location.

Tools Needed: 1/4" hex driver

Tools Provided: 1/8" hex key wrench

1. Remove the base grille. Grasp the grille firmly and pull it toward you. Open the freezer drawer to access the brake feet.

NOTE: To allow the refrigerator to roll easier, raise the brake feet by turning them counterclockwise. The front rollers will be touching the floor.

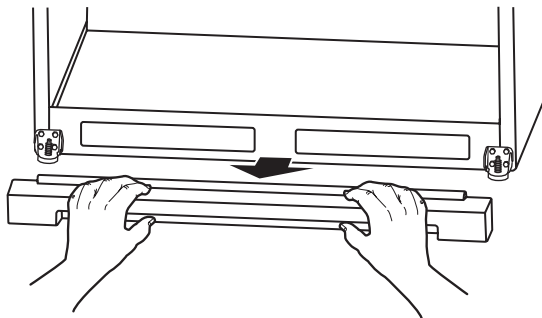

2. Move the refrigerator to its final location.
3. Lower the brake feet, by turning them clockwise, until the rollers are off the floor and both brake feet are snug against the floor. This keeps the refrigerator from rolling forward when opening the refrigerator doors or freezer drawer.

IMPORTANT: If you need to make further adjustments involving the brake feet, you must turn both brake feet the same amount to keep the refrigerator level.

4. Make sure the doors close easily. If you are satisfied with the door opening and closing, skip the next section and go to "Align the Doors." If, however, the doors do not close easily or the doors pop open, adjust the tilt.

To Adjust the Cabinet Tilt:

- Open the freezer drawer. Use a 1/4" hex driver to turn both brake feet clockwise the same amount. This will raise the front of the refrigerator. It may take several turns to allow the doors to close easier.

NOTE: Having someone push against the top of the refrigerator takes some weight off the brake feet. This makes it easier to turn them.

Style 1

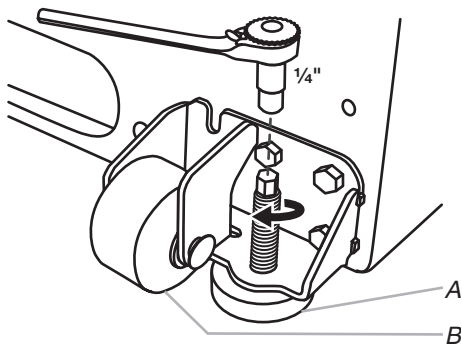

A. Brake foot
B. Front roller

Style 2

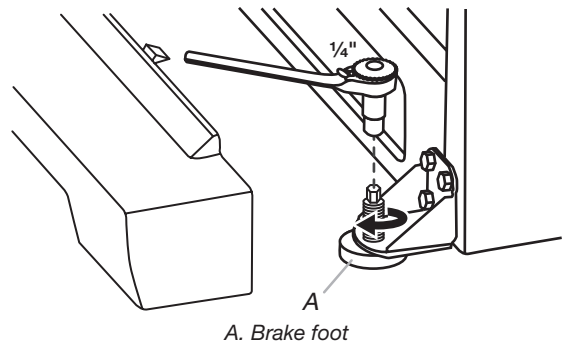

5. Make sure the doors are even at the top and that the space between the bottom of the refrigerator doors and the top of the freezer drawer is even. If necessary, align the doors.

To Align the Doors:

- Keeping both refrigerator doors closed, pull out the freezer drawer. Locate the bottom hinge pin of the right-hand refrigerator door. The alignment screw is inside the bottom hinge pin.

- Insert the short end of the 1/8" hex key wrench (packed with the Door Handle Installation Instructions) into the bottom hinge pin until it is fully engaged in the alignment screw.

To raise the refrigerator door, turn the hex key to the right.
To lower the door, turn the hex key to the left.

- Continue to turn the alignment screw until the doors are aligned.

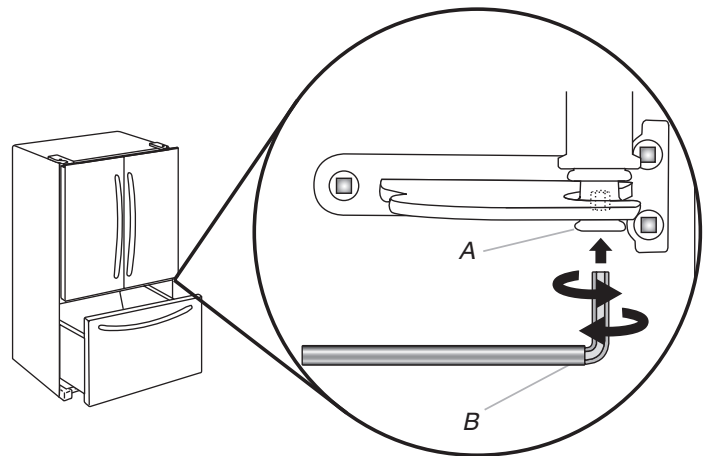

A. Bottom hinge pin
B. 1/8" Hex key wrench

6. Make sure the refrigerator is steady. If the refrigerator seems unsteady or rolls forward when the door or drawer is pulled open, adjust the brake feet.

FILTERS AND ACCESSORIES

To Steady the Refrigerator:

- Open the freezer drawer. Using a 1/4" hex driver, turn both brake feet clockwise the same amount until the brake feet are snug against the floor. Check again. If not satisfied, continue to adjust the brake feet by half turns of the screw until the refrigerator does not roll forward when the drawer is opened.

NOTE: Having someone push against the top of the refrigerator takes some weight off the brake feet. This makes it easier to turn the screws.

7. Replace the base grille by aligning the ends of the grille with the leveling assemblies on each side and snapping the grille into place.

Water Filtration System

Do not use with water that is microbiologically unsafe or of unknown quality without adequate disinfection before or after the system. Systems certified for cyst reduction may be used on disinfected waters that may contain filterable cysts.

Install the Water Filter

1. Locate the accessory packet in the refrigerator and remove the water filter.
2. Take the water filter out of its packaging and remove the cover from the O-rings. Be sure the O-rings are still in place after the cover is removed.

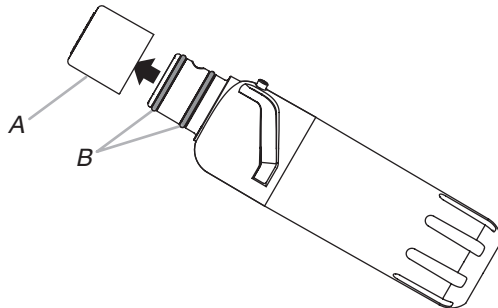

A. O-ring cover
B. O-rings

3. The water filter compartment is located in the right-hand side of the refrigerator ceiling. Push up on the compartment door to release the catch, then lower the door.

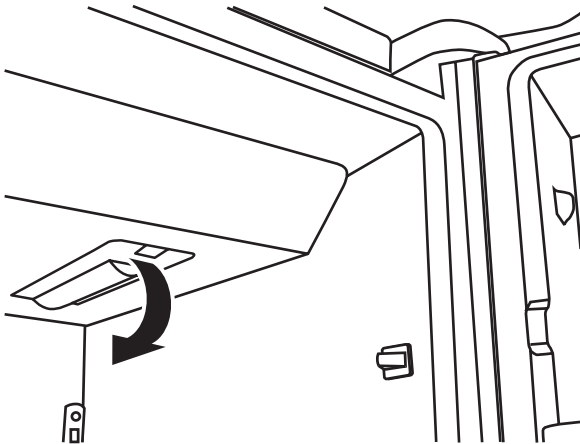

4. Align the arrow on the water filter label with the cutout notch in the filter housing and insert the filter into the housing.
5. Turn the filter clockwise 90 degrees (1/4 turn), until it locks into the housing.

NOTE: If the filter is not correctly locked into the housing, the water dispenser will not operate. Water will not flow from the dispenser.

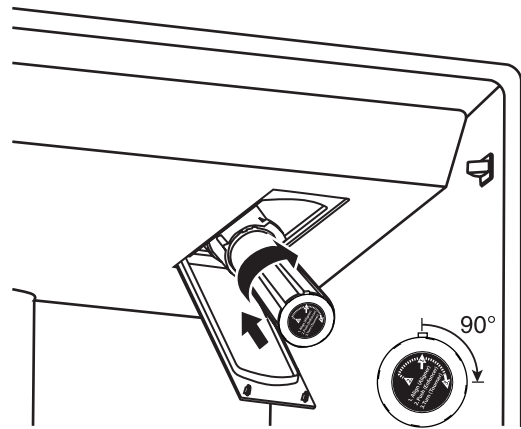

6. While the compartment door is still open, lift the filter up into the compartment. Then, close the filter compartment door completely.
7. Flush the water system. See "Flushing the Water Filter" in the "Water and Ice Dispensers" section.

IMPORTANT: If you do not flush the water system, you may experience dripping and/or decreased flow from the water dispenser.

The Water Filter Status Light

Press **OPTIONS** on the control panel to launch the Options menu. Press **OPTIONS**, under Filter Status, again to display the percentage of filter life remaining (from 99% to 0%). Press **ICE/WATER**, under Back, to return to the Normal screen.

The water filter status lights will help you know when to change your water filter.

- **ORDER FILTER** (yellow) - it is almost time to change the water filter. While you are dispensing water, "Order Filter" will blink seven times and sound an alert tone three times.
- **REPLACE FILTER** (red) - Replace the water filter. While you are dispensing water, "Replace Filter" will blink seven times and an alert tone will sound three times.

FILTERS AND ACCESSORIES

- **RESET** the water filter status tracking feature. After you replace the disposable filter with a new filter, closing the filter compartment door will automatically reset the filter status tracking feature. See “Using the Control(s)” section.

NOTE: “REPLACE FILTER” will remain illuminated if a filter is not installed or is installed incorrectly.

Replace the Water Filter

To purchase a replacement water filter, see “Accessories” in the User Guide, Use and Care Guide or User Instructions.

Replace the disposable water filter when indicated on the water filter status display or at least every 6 months. If water flow to your dispenser or ice maker decreases noticeably, change the water filter sooner.

Install Air Filter (on some models)

An air filter is 15 times more powerful than baking soda at reducing common food odors inside the refrigerator.

On some models, your refrigerator’s accessory packet includes an air filter, which must be installed prior to use.

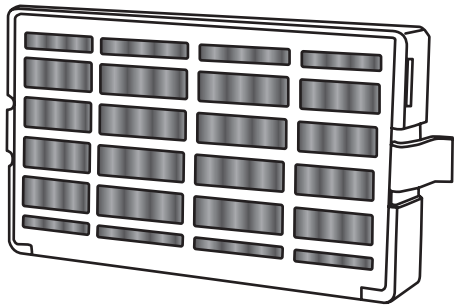

Installing the Air Filter

Install the air filter behind the vented door, located on the rear wall near the top of the refrigerator compartment.

1. Remove the air filter from its packaging.
2. Lift open the vented door.
3. Snap the filter into place.

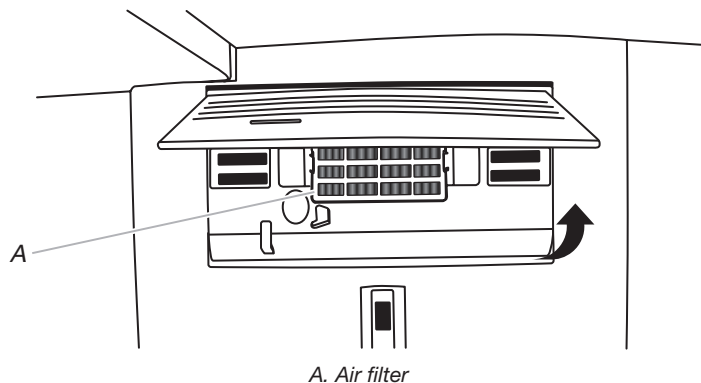

1. Locate the water filter compartment in the right-hand side of the refrigerator ceiling. Push up to release and lower the compartment door.
2. Turn the water filter counterclockwise (to the left), and pull it straight out of the compartment.

NOTE: There may be some water in the filter. Some spilling may occur. Use a towel to wipe up any spills.

3. Install the replacement water filter by following steps 2 through 7 in the “Install the Water Filter” section.

Installing the Filter Status Indicator

The filter comes with a status indicator, which should be activated and installed at the same time the air filter is installed.

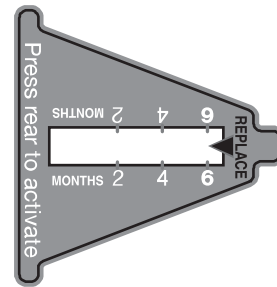

1. Place the indicator face-down on a firm, flat surface.
2. Apply pressure to the bubble on the back of the indicator until the bubble pops to activate the indicator.
3. Lift open the vented air filter door. On some models, there are notches behind the door.

Models with notches:

- With the indicator screen facing outward, slide the indicator down into the notches.

NOTE: The indicator will not easily slide into the notches if the bubble has not been popped.

- Close the air filter door, and check that the indicator is visible through the window in the door.

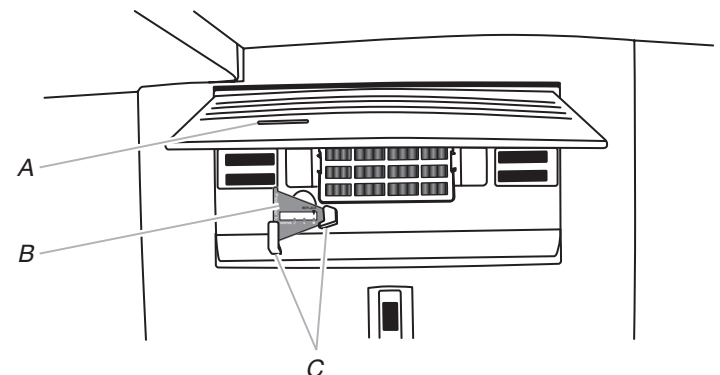

A. Status indicator window
B. Air filter status indicator
C. Notches

FILTERS AND ACCESSORIES

Models without notches:

- Place the indicator somewhere it is easily visible - either inside the refrigerator, or elsewhere in your kitchen or home.

Replacing the Air Filter

The disposable air filter should be replaced every 6 months, when the status indicator has completely changed from white to red.

To order a replacement air filter, contact us. See “Accessories” in the User Guide, Use and Care Guide or User Instructions for information on ordering.

1. Remove the used air filter by squeezing in on the side tabs.
2. Remove the used status indicator.
3. Install the new air filter and filter status indicator using the instructions in the previous sections.

Install Produce Preserver (on some models)

The produce preserver absorbs ethylene, to slow the ripening process of many produce items. As a result, certain produce items will stay fresh longer.

Ethylene production and sensitivity varies depending on the type of fruit or vegetable. To preserve freshness, it is best to separate produce with sensitivity to ethylene from fruits that produce moderate to high amounts of ethylene.

	Sensitivity to Ethylene	Ethylene Production
Apples	High	Very High
Asparagus	Medium	Very Low
Berries	Low	Low
Broccoli	High	Very Low
Cantaloupe	Medium	High
Carrots	Low	Very Low
Citrus Fruit	Medium	Very Low
Grapes	Low	Very Low
Lettuce	High	Very Low
Pears	High	Very High
Spinach	High	Very Low

Installing the Produce Preserver

CAUTION: IRRITANT

MAY IRRITATE EYES AND SKIN. DANGEROUS FUMES FORM WHEN MIXED WITH OTHER PRODUCTS.

Do not mix with cleaning products containing ammonia, bleach or acids. Do not get in eyes, on skin or clothing. Do not breathe dust. Keep out of reach of children.

FIRST AID TREATMENT: Contains potassium permanganate. If swallowed, call a Poison Control Center or doctor immediately. Do not induce vomiting. If in eyes, rinse with water for 15 minutes. If on skin, rinse with water.

1. Find the Produce Preserver housing inside the refrigerator.

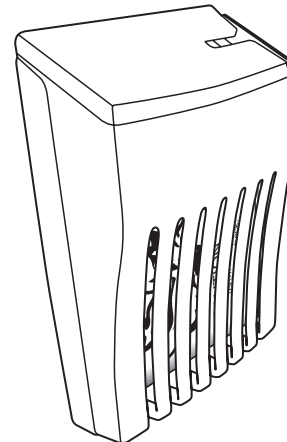

2. Open the housing by pulling up and out on the back.
3. Remove the Produce Preserver pouches from the packaging and place them into the housing.
NOTE: For best performance, always use two pouches.
4. Adhere the Produce Preserver housing to the back wall of the crisper drawer according to the instructions included in the package.

FILTERS AND ACCESSORIES

Installing the Status Indicator

The produce preserver comes with a status indicator, which should be activated and installed at the same time the pouches are installed.

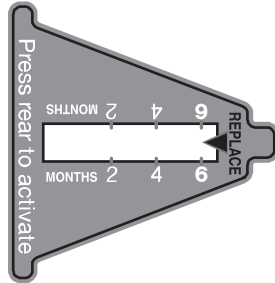

1. Place the indicator face-down on a firm, flat surface.
2. Apply pressure to the bubble on the back of the indicator until the bubble pops to activate the indicator.

3. Slide open the cap on the top of the produce preserver housing.
4. Place the indicator in the top of the housing, facing outward.
5. Slide the cap closed, and check that the indicator is visible through the rectangular hole in the cap.

NOTE: The cap will not easily close if the indicator's bubble has not been popped.

Replacing the Produce Preserver

The disposable pouches should be replaced every 6 months or when the status indicator changes completely from white to red. To order replacements, contact us. See "Accessories" for information on ordering.

1. Remove the used pouches from the produce preserver housing.
2. Remove the used status indicator.
3. Install the replacement pouches and status indicator using the instructions in the previous sections.

Accessories

The following accessories are available for your refrigerator. To order an accessory, contact us and ask for the Part Number.

In the U.S.A., visit our webpage www.whirlpool.com/accessories or call 1-800-901-2042.

In Canada, visit our webpage www.whirlpool.ca or call 1-800-807-6777.

Affresh® Stainless Steel Cleaner:

In U.S.A., order Part #W10355016

In Canada, order Part #W10355016B

Affresh® Stainless Steel Wipes:

In U.S.A., order Part #W10355049

In Canada, order Part #W10355049B

Affresh® Kitchen & Appliance Cleaner:

In U.S.A., order Part #W10355010

In Canada, order Part #W10355010B

Water Filter:

Order Part #W10413645A or FILTER2

Air Filter:

Order Part #W10311524 or AIR1

Produce Preserver:

Order Part # W10346771A or FRESH1

Water Filter, Air Filter and Produce Preserver Bundle Pack:

Order Part # W10413643BL

REFRIGERATOR USE

Opening and Closing Doors

There are two refrigerator compartment doors. The doors can be opened and closed either separately or together.

There is a vertically-hinged seal on the left refrigerator door.

- When the left-hand refrigerator door is opened, the hinged seal automatically folds inward so that it is out of the way.
- When both doors are closed, the hinged seal automatically forms a seal between the two doors.

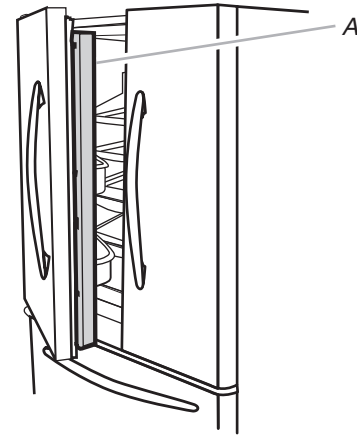

A. Hinged seal

Using the Controls

The controls are located above the external dispenser.

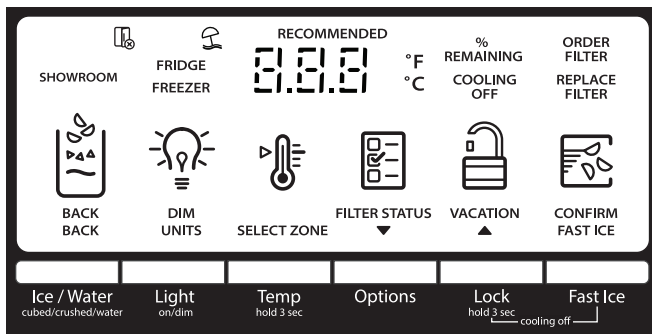

IMPORTANT: The display screen on the dispenser control panel will turn off automatically and enter “sleep” mode when the control buttons and dispenser paddles have not been used for 2 minutes or more. Press any control button to reactivate the display screen. The home screen will appear as shown.

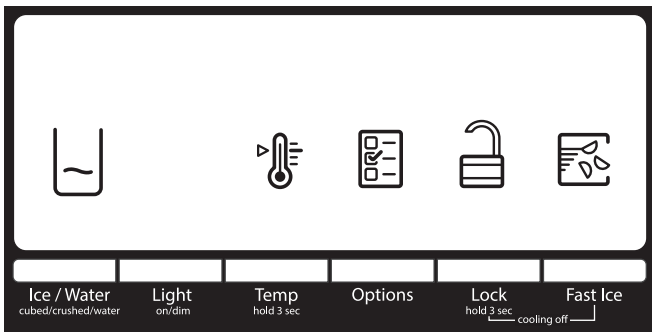

Viewing and Adjusting Temperature Set Points

For your convenience, your refrigerator and freezer controls are preset at the factory.

When you first install your refrigerator, make sure that the controls are still set to the recommended set points. The factory recommended set points are 37°F (3°C) for the refrigerator and 0°F (-18°C) for the freezer.

IMPORTANT:

- Wait 24 hours before you put food into the refrigerator. If you add food before the refrigerator has cooled completely, your food may spoil.

NOTE: Adjusting the set points to a colder than recommended setting will not cool the compartments any faster.

- If the temperature is too warm or too cold in the refrigerator or freezer, first check the air vents to be sure they are not blocked before adjusting the controls.

- The recommended settings should be correct for normal household use. The controls are set correctly when milk or juice is as cold as you like and when ice cream is firm.

NOTE: Areas such as a garage, basement or porch, may have higher humidity or extreme temperatures. You may need to adjust the temperature away from the recommended settings to accommodate for these conditions.

- Wait at least 24 hours between adjustments. Recheck the temperatures before other adjustments are made.

View Temperature Set Points

1. Press and hold TEMP for 3 seconds to activate Temperature mode.

NOTE: To view temperature in degrees Celsius, press the LIGHT button, under Units, when adjust mode is activated. To return the display setting to Fahrenheit, press the LIGHT button again.

REFRIGERATOR USE

When Temperature mode is activated, press TEMP to toggle between Fridge and Freezer. The display will show the temperature set point of the selected compartment, and temperature adjusting information will appear on the display screen.

Recommended Refrigerator Temperature

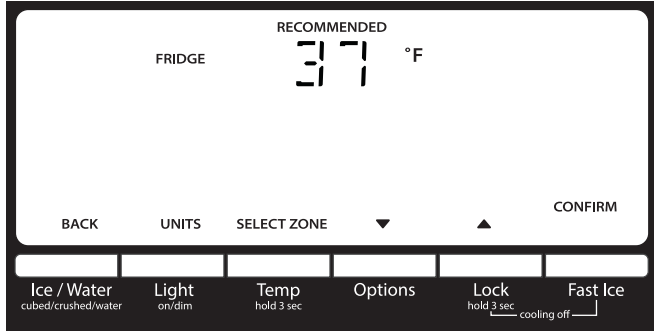

Recommended Freezer Temperature

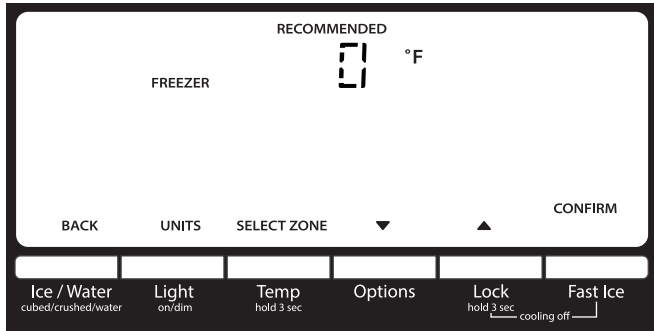

Adjust Temperature Set Points

Refrigerator set point range: 33°F to 45°F (0°C to 7°C).

Freezer set point range: -5°F to 5°F (-21°C to -15°C).

1. After Temperature mode is activated, press TEMP again to Select Zone (Fridge or Freezer). The display will show the temperature set point of the selected compartment, as shown.
2. Press LOCK to raise the set point, or press OPTIONS to lower the set point.
3. When you have finished viewing (and adjusting if desired) the Fridge zone set point, press TEMP, under Select Zone, to change the display to show the Freezer zone set point. When the zone has been changed, "FREEZER" appears on the display screen.
4. Press the LOCK button to raise the set point, or press the OPTIONS button to lower the set point.

Save/Confirm Temperature Settings

- When you have finished adjusting both the refrigerator and freezer set points, press FAST ICE to confirm and to save the settings.

NOTE: To exit Temperature mode without saving changes, press the ICE/WATER button under Back at any time, or allow about 60 seconds of inactivity. The temperature mode will turn off automatically and return to the normal screen.

When adjusting temperature set points, use the following chart as a guide

CONDITION:	TEMPERATURE ADJUSTMENT:
REFRIGERATOR too cold	REFRIGERATOR Setting 1° higher
REFRIGERATOR too warm	REFRIGERATOR Setting 1° lower
FREEZER too cold	FREEZER Setting 1° higher
FREEZER too warm / Too little ice	FREEZER Setting 1° lower

Cooling On/Off

Your refrigerator and freezer will not cool when cooling is turned off.

- To turn Off cooling, press and hold LOCK and FAST ICE at the same time for 3 seconds. "Cooling Off" will blink seven times and then remain lit as shown.

IMPORTANT:

- To avoid unintentionally locking the dispenser or changing other settings, press both buttons at exactly the same time.
- When cooling is off, the dispenser paddles and all controls except Lock and Fast Ice are disabled.

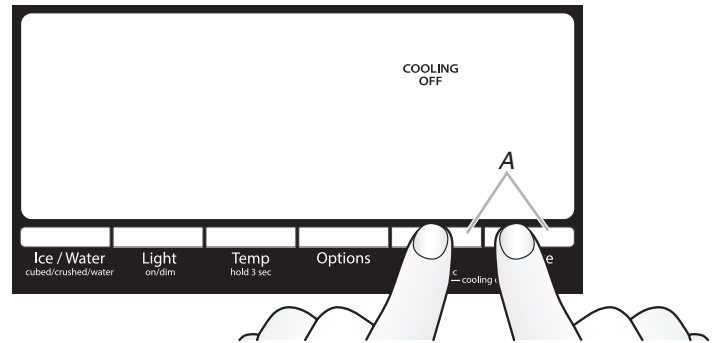

A. Press LOCK and FAST ICE at the same time.

- When cooling is off, press and hold LOCK and FAST ICE for 3 seconds to turn On cooling.

Options

Press the OPTIONS button to open the Options menu and select between Filter Status or Vacation mode.

Press the ICE/WATER button, under "Back," at any time to return to the Home screen.

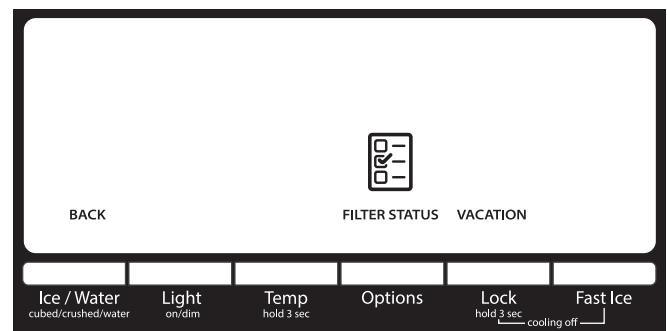

REFRIGERATOR USE

Fast Ice

The Fast Ice feature assists with temporary periods of heavy ice use by increasing ice production.

- To turn on the Fast Ice feature, press FAST ICE. When the feature is on, the Fast Ice icon will appear on the display. The Fast Ice feature will remain on for 24 hours unless manually turned off.



- To manually turn off the Fast Ice feature, press FAST ICE again. When the feature has been turned off, the Fast Ice icon will disappear from the display.

Filter Status

Displays the percentage of use remaining in the water filter (from 100% remaining to 0% remaining).

To access Filter Status, press the OPTIONS button to access the Options menu, then press OPTIONS, under Filter Status, to display the percent of life remaining in the water filter.

ALSO

The water filter status lights will let you know when to change your water filter.

- ORDER FILTER (Yellow) - Order a replacement water filter.
- REPLACE FILTER (Red) - Replace the water filter. Replacing the disposable water filter will automatically reset the water filter status tracking feature. See "Water Filtration System."

NOTE: REPLACE FILTER will remain illuminated if a filter is not installed or installed incorrectly.

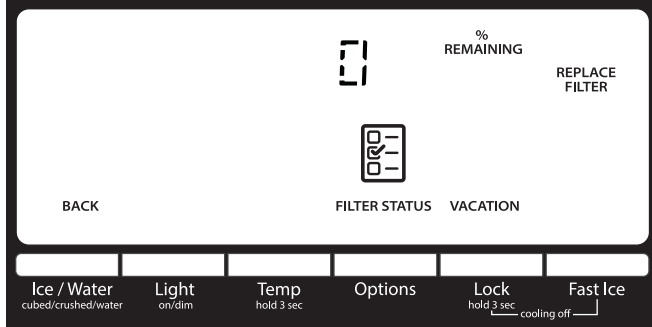

Vacation Mode

In Vacation Mode, the freezer will defrost less often to conserve energy.

- To turn on Vacation mode, press the OPTIONS button to access the Options menu, then press LOCK, under "Vacation," to activate the feature. When the feature is on, the Vacation icon will appear on the dispenser display screen as shown.

- To turn off Vacation Mode, press the OPTIONS button to access the Options menu, then press LOCK to turn off the feature. The Vacation icon will disappear, and the screen will display the settings as they were before Vacation Mode was turned on.



NOTES:

- During the first hour after Vacation Mode is turned on, opening and closing the refrigerator door will not affect the setting. After 1 hour has passed, opening and closing the refrigerator door will turn off Vacation Mode.
- While in Vacation Mode, if Fast Ice is turned on or the Door Ajar alarm sounds, Vacation Mode will be canceled.

Additional Features

Door Ajar Alarm

The Door Ajar Alarm feature sounds an alarm when the refrigerator door(s) or freezer drawer is open for 5 minutes and cooling is turned on. The alarm will repeat every 2 minutes. Close all doors and drawer to turn it off. The feature then is reset and will reactivate when either door is left open again for 5 minutes.

- NOTE: To mute the audible alarm while keeping the doors open, such as while cleaning the inside of the refrigerator, press any button on the control panel. The alarm sound will be temporarily turned off, but the Door Ajar icon will still be displayed on the dispenser control panel.



Disabling Sounds

- To turn off control and dispenser sounds, press and hold ICE/WATER and FAST ICE at the same time for 3 seconds. All normal operating tones are disabled. Only alert tones will be audible.
- To turn on control and dispenser sounds, press and hold ICE/WATER and FAST ICE at the same time for 3 seconds.

Showroom Mode

This mode is used only when the refrigerator is on display in a retail store. If you unintentionally turn on Showroom mode, the word "Showroom" will light up on the display. Exit Showroom mode by pressing and holding LIGHT and LOCK at the same time for 3 seconds.

REFRIGERATOR USE

Water and Ice Dispensers

IMPORTANT:

- Allow 3 hours for the refrigerator to cool down and chill water.
- Allow 24 hours to produce the first batch of ice. Discard the first three batches of ice produced.
- The dispensing system will not operate when either the refrigerator door or freezer drawer is open.

Flush the Water System

Air in the water dispensing system can cause the water dispenser to drip. After connecting the refrigerator to a water source or replacing the water filter, flush the water system.

Flushing the water dispensing system forces air from the water line and filter and prepares the water filter for use. Additional flushing may be required in some households.

NOTE: As air is cleared from the system, water may spurt out of the dispenser.

1. Using a sturdy container, depress and hold the water dispenser paddle for 5 seconds.
2. Release the dispenser paddle for 5 seconds. Repeat steps 1 and 2 until water begins to flow.
3. Once water begins to flow, continue depressing and releasing the dispenser pad (5 seconds on, 5 seconds off) until a total of 3 gal. (12 L) has been dispensed.

Dispensing

Press ICE/WATER to toggle through the following choices in a continuous loop:

- Water (default) - Dispenses water
- Cubed - Dispenses cubed ice
- Crushed - Dispenses crushed ice

NOTES:

- The word "ICE" appears on the display screen when either crushed or cubed ice is selected.
- For crushed ice, cubes are crushed before being dispensed. This may cause a slight delay when dispensing crushed ice. Noise from the ice crusher is normal, and pieces of ice may vary in size.
- When changing from crushed to cubed, a few ounces of crushed ice will be dispensed along with the first cubes.

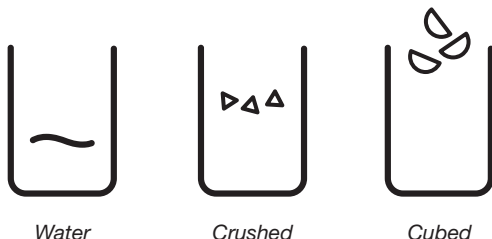

The Water Dispenser

IMPORTANT:

- Dispense at least 1 qt (1 L) of water every week to maintain a fresh supply.
- If the flow of water from the dispenser decreases, it could be caused by low water pressure.
 - With the water filter removed, dispense 1 cup (237 mL) of water. If 1 cup (237 mL) of water is dispensed in 8 seconds or less, the water pressure to the refrigerator meets the minimum requirement.
 - If it takes longer than 8 seconds to dispense 1 cup (237 mL) of water, the water pressure to the refrigerator is lower than recommended. See "Water Supply Requirements" and "Problem Solver" or "Troubleshooting" for suggestions.

To Dispense Water:

1. Select water.
2. Press a sturdy glass against the dispenser paddle.

NOTE: While dispensing water and for 3 seconds after dispensing has stopped, the digital display will show how much water has been dispensed.
3. Remove the glass to stop dispensing.

The Ice Dispenser

IMPORTANT:

- If the ice cubes are hollow or have an irregular shape, it could be because of low water pressure. See "Water Supply Requirements."
- Ice travels from the ice storage bin through the dispenser chute to the dispenser. To turn off the ice maker, see "Ice Maker and Storage Bin."

To Clean the Ice Dispenser Chute:

Humidity causes ice to naturally clump together. Ice particles can build up until the ice dispenser chute becomes blocked.

If ice is not dispensed regularly, it may be necessary to empty the ice storage bin and clean the ice delivery chute, the ice storage bin and the area beneath the storage bin every 2 weeks.

- Remove the ice clogging the storage bin and delivery chute, using a plastic utensil if necessary.
- Clean the ice delivery chute and the bottom of the ice storage bin using a warm, damp cloth, then dry thoroughly.

REFRIGERATOR USE

To Dispense Ice:

1. Select the desired type of ice. To switch between cubed ice and crushed ice, press ICE/WATER.

⚠ WARNING



Cut Hazard

Use a sturdy glass when dispensing ice.

Failure to do so can result in cuts.

2. Press a sturdy glass against the dispenser paddle. Hold the glass close to the dispenser opening so ice does not fall outside of the glass.
IMPORTANT: You do not need to apply a lot of pressure to the paddle to activate the ice dispenser. Pressing hard will not make the ice dispense faster or in greater quantities.
3. Remove the glass to stop dispensing.

NOTE: Ice may continue to dispense for several seconds after removing the glass from the dispenser paddle. The dispenser may continue to make noise for a few seconds after dispensing.

The Dispenser Light

When you use the dispenser, the light will automatically turn on.

To turn on the light when you are not dispensing:

Press LIGHT to toggle through the following choices in a continuous loop:

- OFF (default) - The dispenser light is off
- ON - The dispenser light remains on at 100% brightness
- DIM - The dispenser light remains on at 50% brightness

Ice Maker and Ice Storage Bin (on some models)

IMPORTANT: To avoid low ice production and poor quality ice, flush the water system before turning on the ice maker. See “Water Dispenser.”

- Allow 24 hours to produce the first batch of ice. Discard the first three batches of ice produced. Allow 2 to 3 days for the storage bin to fill completely following installation.
- The quality of your ice will be only as good as the quality of the water supplied to your ice maker. Avoid connecting the ice maker to a softened water supply. Water softener chemicals (such as salt) can damage parts of the ice maker and lead to poor quality ice. If a softened water supply cannot be avoided, make sure the water softener is operating properly and is well maintained.

The dispenser lights are LEDs that cannot be changed. If it appears that your dispenser lights are not working, see “Troubleshooting” for more information.

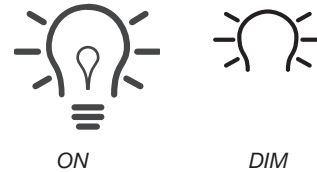

The Dispenser Lock

The dispenser can be turned off for easy cleaning or to avoid unintentional dispensing by small children and pets.

NOTE: The lock feature does not shut off power to the refrigerator, to the ice maker, or to the dispenser light. It simply deactivates the controls and dispenser paddles. To turn off the ice maker, see “Ice Maker and Storage Bin.”

- Press and hold LOCK for 3 seconds to lock the dispenser.
 - Press and hold LOCK a second time to unlock the dispenser.
- The display screen indicates when the dispenser is locked.



- If the ice in the storage bin clumps together, break up ice using a plastic utensil and discard. Do not use anything sharp to break up the ice. This can cause damage to the ice bin and the dispenser mechanism.
- Do not store anything in the ice storage bin.

Ice Production Rate

- The ice maker should produce approximately 3 lbs (1.4 kg) of ice per day under normal operation.
- To increase ice production, select the increased ice production feature from the Options menu on the control panel. See “Using the Control(s).”

REFRIGERATOR USE

Style 1 - Ice Maker in the Refrigerator (on some models)

The ice maker is located on the left-hand side of the refrigerator compartment ceiling. Ice cubes are ejected into the ice storage bin, located on the left-hand refrigerator door.

Turn the Ice Maker On/Off

1. Push up on the latch on the left-hand side of the ice compartment to open the door.

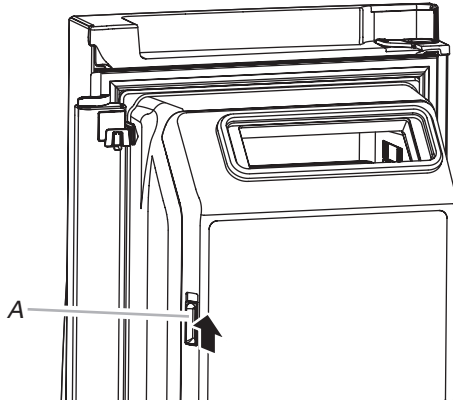

A. Ice compartment door latch

2. Turn on the ice maker by moving the switch to the (left) ON position.

NOTES:

- To manually turn off the ice maker, move the control to the OFF (right) position.
- Your ice maker has an automatic shutoff. The sensor will automatically stop ice production if the storage bin is full, if the door is open or the storage bin is removed. The control will remain in the ON (left) position.

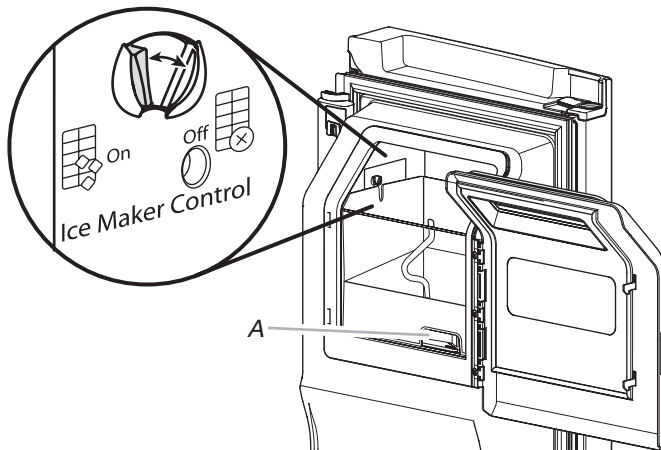

A. Ice storage bin release latch

3. Close the ice compartment door.

Remove and Replace the Ice Storage Bin

- Remove the ice storage bin by inserting your fingers into the hole at the base of the bin and squeezing the latch to release the bin from the compartment. Lift the storage bin up and pull it straight out.
- Replace the storage bin inside the ice compartment and push down to make sure it is firmly in place.

Style 2 - Ice Maker in the Freezer (on some models)

Turn the Ice Maker On/Off

To turn the ice maker ON, simply lower the wire shutoff arm.

To manually turn the ice maker OFF, lift the wire shutoff arm to the OFF (arm up) position and listen for the click.

NOTE: Your ice maker has an automatic shutoff. As ice is made, the ice cubes will fill the ice storage bin and the ice cubes will raise the wire shutoff arm to the OFF (arm up) position. Do not force the wire shutoff arm up or down.

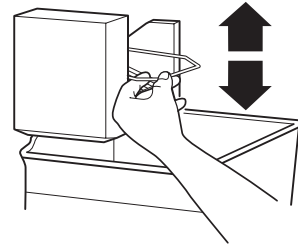

NOTE: Turn off the ice maker before removing the ice storage bin to serve ice or to clean the bin. This will keep the ice cubes from dropping out of the ice maker and into the freezer compartment. After replacing the ice storage bin, turn on the ice maker.

REFRIGERATOR FEATURES

Important information to know about glass shelves and covers:

Do not clean glass shelves or covers with warm water when they are cold. Shelves and covers may break if exposed to sudden temperature changes or impact, such as bumping. Tempered glass is designed to shatter into many small, pebble-size pieces. This is normal. Glass shelves and covers are heavy. Use both hands when removing them to avoid dropping.

Refrigerator Shelves

The shelves in your refrigerator are adjustable to meet your individual storage needs.

Storing similar food items together in your refrigerator and adjusting the shelves to fit different heights of items will make finding the exact item you want easier. It will also reduce the amount of time the refrigerator door is open, and save energy.

Shelves and Shelf Frames

To remove and replace a shelf/shelf frame:

1. Remove the shelf/frame by tilting it up at the front and lifting it out of the shelf supports.
2. Replace the shelf/frame by guiding the rear shelf hooks into the shelf supports. Tilt the front of the shelf up until rear shelf hooks drop into the shelf supports.
3. Lower the front of the shelf and make sure that the shelf is in position.

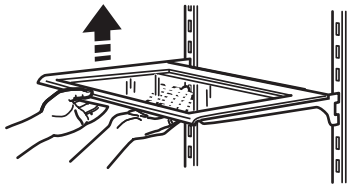

MicroEdge® Glo shelves (on some models):

- The hooks on the rear of the shelf must be fully engaged in the shelf supports to maintain proper electrical flow.
- No more than two shelves with under-shelf lighting may be used in the refrigerator at one time.

Tuck Away Shelf (on some models)

To retract and extend the front section of the shelf:

1. To retract the front-section of the shelf, slightly lift up on the front edge and push the adjustable portion of the shelf back toward the rear of the refrigerator.
2. Extend the front of the shelf by pulling the retracted portion of the shelf outward until it is fully extended.

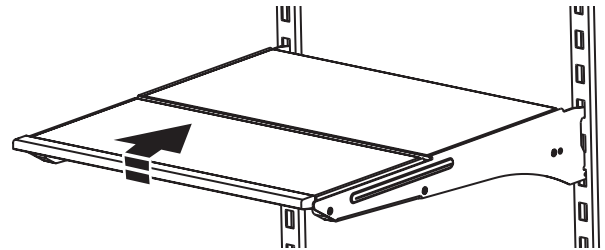

Crisper Drawers/Pantry Drawer/Crisper Cover

To remove and replace the drawers:

1. Slide the drawers straight out to the stop. Lift the drawers from the rails and pull them out the rest of the way.
2. Replace the drawers by placing them on the rails and pushing them back into position past the drawer stop.

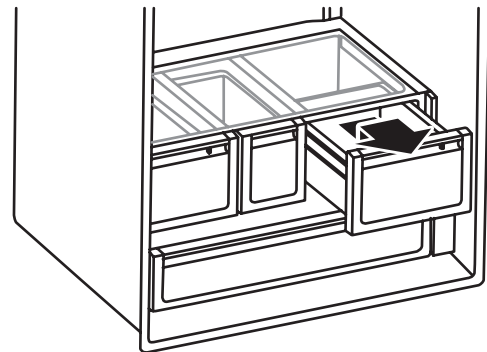

REFRIGERATOR FEATURES

To remove the crisper(s) cover:

1. Remove crisper drawers.
2. Holding the glass insert firmly with one hand, press up in center of glass insert until it rises above the plastic frame. Gently slide the glass insert forward to remove.
3. Lift the cover frame up and remove it.

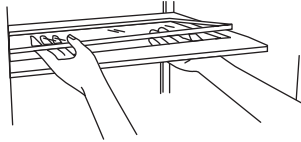

To replace crisper(s) cover:

1. Fit back of cover frame into supports on side walls of the refrigerator and lower the front of the cover frame into place.
2. Slide rear of glass insert into cover frame and lower front into place.
3. Replace crisper drawers.

Crisper Humidity Control

You can control the amount of humidity in the moisture-sealed crisper. Adjust the control to any setting between LOW (open) and HIGH (closed).

LOW - Move control to the far left-hand side to allow moist air out of the crisper for best storage of fruits and vegetables with skins.

- Fruit: Wash, let dry and store in refrigerator in plastic bag or crisper. Do not wash or hull berries until they are ready to use. Sort and keep berries in original container in crisper, or store in a loosely closed paper bag on a refrigerator shelf.
- Vegetables with skins: Place in plastic bags or plastic container and store in crisper.

HIGH - Move control to the far right-hand side to keep moist air in the crisper for best storage of fresh, leafy vegetables.

- Leafy vegetables: Wash in cold water, drain and trim or tear off bruised and discolored areas. Place in plastic bag or plastic container and store in crisper.

Moisture Control



Temperature-Controlled Drawer

IMPORTANT: This control sets the temperature for only this drawer. It does not set the temperature for, or turn off cooling to the refrigerator or freezer compartments.

The full-width, temperature-controlled drawer can be used to store large deli trays, fresh meat, beverages or other items that you want to store at an optimum temperature.

Depending on your model, you will have either an Electronic Control or a Manual Control. Use the directions specific to your model.

NOTE: Do not place leafy vegetables in the temperature controlled drawer. The colder temperatures could damage leafy produce.

NOTE: If no button is pressed, the control will revert to Cold Drinks, the default setting.

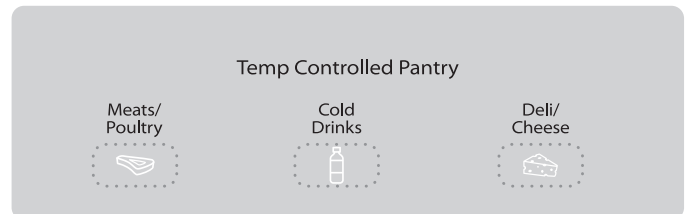

Style 1 - Electronic Control

For your convenience, temperatures have been preset for the optimum storage of fresh meat and poultry, cold drinks, and deli and cheese. These preset temperatures cannot be adjusted.

Press the desired temperature setting for the items to be stored in the drawer. As it is pressed, each icon will light up.

- Meats/Poultry - 32°F (0°C)
- Cold Drinks (default setting) - 36°F (2°C)
- Deli/Cheese - 39°F (4°C)

Style 2 - Manual Control

Slide the control to the temperature setting best suited for the items stored in the drawer.

- Meat - Coldest
- Vegetables - Least cold

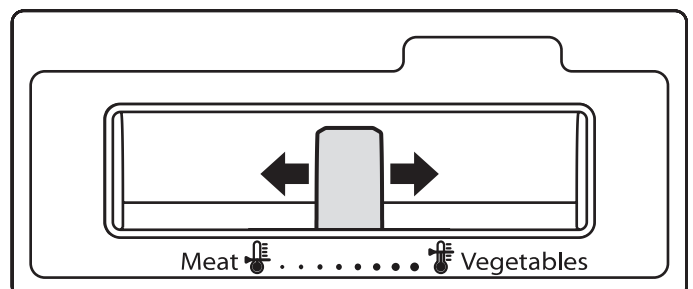

REFRIGERATOR FEATURES

Drawer Removal and Replacement

To remove the drawer:

1. Push the drawer completely closed.
2. Lift up the front of the drawer and pull it straight out.

To replace the drawer:

1. Push the metal glide rails to the rear of the refrigerator.
2. Place the drawer onto the glide rails. While tilting the rear of the drawer upward, slide the drawer toward the rear of the refrigerator.

Drawer Divider

To remove the divider:

1. Pull the drawer out to its full extension.
2. Lift the front of the divider and lift the divider out.

To replace the divider:

1. Position the divider so that the features on the bottom of the divider align with the matching features in the drawer.
2. Lower the divider into place.

Door Bins

To remove and replace the bins:

1. Remove the bin by lifting it up and pulling it straight out.
2. Replace the bin by sliding it in above the desired support and pushing it down until it stops.

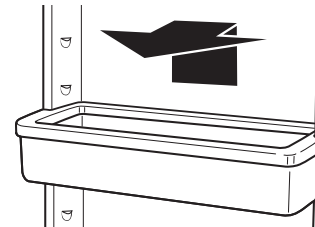

Pizza Pocket and Drawer Divider

The drawer divider is not removable. For storage flexibility, the divider can be moved a few inches to either side allowing you to store larger items in one section of the freezer drawer.

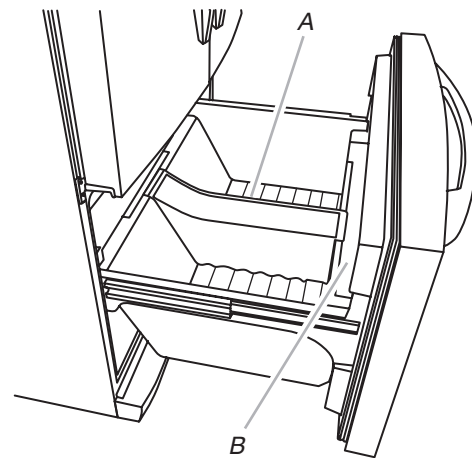

A. Drawer divider
B. Pizza pocket

Meat Storage Guide

Store most meat in original wrapping as long as it is airtight and moisture-proof. Rewrap if necessary. See the following chart for storage times. When storing meat longer than the times given, freeze the meat.

Fresh fish or shellfish.....use same day as purchased
Chicken, ground beef, variety meats (liver)1-2 days
Cold cuts, steaks/roasts3-5 days
Cured meats.....7-10 days

Leftovers - Cover leftovers with plastic wrap, aluminum foil, or plastic containers with tight lids.

REFRIGERATOR CARE

Cleaning

⚠ WARNING



Explosion Hazard

Use nonflammable cleaner.

Failure to do so can result in death, explosion, or fire.

Both the refrigerator and freezer sections defrost automatically. However, clean both sections about once a month to avoid buildup of odors. Wipe up spills immediately.

Exterior Cleaning

Please see the exterior cleaning information specific to your model.

Style 1: Smooth Door

IMPORTANT: Damage to smooth finish due to improper use of cleaning products or using non-recommended cleaning products is not covered under the warranty. Sharp or blunt instruments will mar the finish.

DO USE	DO NOT USE
✓ Soft, clean cloth	✗ Abrasive cloths
	✗ Paper towels or newsprint
	✗ Steel-wool pads
✓ Warm, soapy water with a mild detergent	✗ Abrasive powders or liquids
	✗ Window sprays
	✗ Ammonia
	✗ Acidic or vinegar-based cleaners
	✗ Oven cleaners
	✗ Flammable fluids

NOTE: Paper towels scratch and may dull the clear coat of the painted door. To avoid possible damage, use only soft, clean cloths to polish and wipe the door.

Style 2: Stainless Steel

IMPORTANT:

- Damage to stainless steel finish due to improper use of cleaning products, or using non-recommended cleaning products, is not covered under the warranty.

DO USE	DO NOT USE
✓ Soft, clean cloth	✗ Abrasive cloths
	✗ Paper towels or newsprint
	✗ Steel-wool pads
✓ Warm, soapy water with a mild detergent	✗ Abrasive powders or liquids
	✗ Ammonia
	✗ Citrus-based cleaners
	✗ Acidic or vinegar-based cleaners
	✗ Oven cleaners
✓ For heavy soil, use ONLY a stainless steel cleaner designed for appliances. To order the cleaner, see the "Accessories" section.	✗ Stainless steel cleaner is for stainless steel parts only! Do not allow the stainless steel cleaner and polish to come into contact with any plastic parts such as the trim pieces, dispenser covers, or door gaskets.

NOTES:

- If unintentional contact does occur, clean plastic part with a sponge and mild detergent in warm water. Dry thoroughly with a soft cloth.
- Just because a cleaner is a liquid does not mean it is nonabrasive. Many liquid cleansers formulated to be gentle on tile and smooth surfaces still damage stainless steel.
- Citric acid permanently discolors stainless steel. To avoid damaging the finish of your stainless steel refrigerator:

Do not allow these substances to remain on the finish:

✗ Mustard	✗ Citrus-based sauces
✗ Tomato juice	✗ Citrus-based products
✗ Marinara sauce	

Interior Cleaning

1. Unplug refrigerator or disconnect power.
2. Hand wash, rinse, and dry removable parts and interior surfaces thoroughly. Use a clean sponge or soft cloth and a mild detergent in warm water.

NOTE: Do not use abrasive or harsh cleaners such as window sprays, scouring cleansers, flammable fluids, cleaning waxes, concentrated detergents, bleaches, or cleansers containing petroleum products on plastic parts, interior and door liners, or gaskets.

3. Plug in refrigerator or reconnect power.

Condenser Cleaning

There is no need for routine condenser cleaning in normal home operating environments. If the environment is particularly greasy or dusty or there is significant pet traffic in the home, the condenser should be cleaned every 6 months to ensure maximum efficiency.

If you need to clean the condenser, please call for service.

1. Unplug refrigerator or disconnect power.
2. Remove the base grille.

Lights

The lights in both the refrigerator and freezer compartments are LEDs, which do not need to be replaced. If the lights do not illuminate when the door or drawer is opened, call for assistance or service. In the U.S.A., call **1-800-253-1301**. In Canada, call **1-800-807-6777**.

Vacation and Moving Care

Vacations

If You Choose to Leave the Refrigerator On While You're Away:

1. Use up any perishables and freeze other items.
2. If your refrigerator has an automatic ice maker and is connected to the household water supply, turn off the water supply to the refrigerator. Property damage can occur if the water supply is not turned off.
3. If you have an automatic ice maker, turn off the ice maker.
NOTE: Depending on your model, raise the wire shutoff arm to OFF (up) position, or press the switch to OFF.
4. Empty the ice bin.

If You Choose to Turn Off the Refrigerator Before You Leave:

1. Remove all food from the refrigerator.
2. If your refrigerator has an automatic ice maker:
 - Turn off the water supply to the ice maker at least one day ahead of time.
 - When the last load of ice drops, raise the wire shutoff arm to the OFF (up) position or press the switch to OFF, depending on your model.
3. Empty the ice bin.
4. Turn off the Temperature control(s). See "Using the Control(s)."
5. Clean refrigerator, wipe it, and dry well.
6. Tape rubber or wood blocks to the tops of both doors to prop them open far enough for air to get in. This stops odor and mold from building up.

3. Use a vacuum cleaner with a soft brush to clean the grille, the open areas behind the grille and the front surface area of the condenser.
4. Replace the base grille when finished.
5. Plug in refrigerator or reconnect power.

Moving

When you are moving your refrigerator to a new home, follow these steps to prepare it for the move.

1. If your refrigerator has an automatic ice maker:
 - Turn off the water supply to the ice maker at least 1 day ahead of time.
 - Disconnect the water line from the back of the refrigerator.
 - When the last load of ice drops, press the switch to OFF either on the ice maker or the control, depending on your model.
2. Remove all food from the refrigerator and pack all frozen food in dry ice.
3. Empty the ice bin.
4. Turn off the Temperature control(s). See "Using the Control(s)."
5. Unplug refrigerator.
6. Clean, wipe, and dry thoroughly.
7. Take out all removable parts, wrap them well, and tape them together so they don't shift and rattle during the move.
8. Depending on the model, raise the front of the refrigerator so it rolls more easily OR raise the leveling screws so they don't scrape the floor. See "Adjust the Door(s)" or "Door Closing and Door Alignment."
9. Tape the doors closed, and tape the power cord to the back of the refrigerator.

When you get to your new home, put everything back and refer to the "Installation Instructions" section for preparation instructions. Also, if your refrigerator has an automatic ice maker, remember to reconnect the water supply to the refrigerator.

TROUBLESHOOTING

First try the solutions suggested here. If you need further assistance or more recommendations that may help you avoid a service call, refer to the warranty page in this manual, visit www.whirlpool.com/product_help.

In Canada, visit www.whirlpool.ca.

Contact us by mail with any questions or concerns at the address below:

In the U.S.A.:

Whirlpool Brand Home Appliances
Customer eXperience Center
553 Benson Road
Benton Harbor, MI 49022-2692

In Canada:

Whirlpool Brand Home Appliances
Customer eXperience Centre
200 – 6750 Century Ave.
Mississauga, Ontario L5N 0B7

Please include a daytime phone number in your correspondence.

Operation

⚠ WARNING



Electrical Shock Hazard

Plug into a grounded 3 prong outlet.

Do not remove ground prong.

Do not use an adapter.

Do not use an extension cord.

Failure to follow these instructions can result in death, fire, or electrical shock.

PROBLEM	POSSIBLE CAUSES	SOLUTIONS
The refrigerator will not operate	Check electrical supply	Plug the power cord into a grounded 3 prong outlet. Do not use an extension cord. Make sure there is power to the outlet. Plug in a lamp to see if the outlet is working. Reset a tripped circuit breaker. Replace any blown fuses. NOTE: If problems continue, contact an electrician.
	Check controls	Make sure the controls are turned on. See “Using the Control(s).”
	New installation	Allow 24 hours following installation for the refrigerator to cool completely. NOTE: Adjusting the temperature controls to the coldest setting will not cool either compartment more quickly.
	Refrigerator control is in Showroom mode (on some models)	If the refrigerator is in Showroom mode, cooling is turned off and “Showroom” will be illuminated on the control panel. See “Using the Control(s)” for more information.

TROUBLESHOOTING

PROBLEM	POSSIBLE CAUSES	SOLUTIONS
The motor seems to run too much	High efficiency compressor and fans	Larger, more efficient refrigerators run longer at lower, more energy efficient speeds.
	The room or outdoor temperature is hot.	It is normal for the refrigerator to work longer under these conditions. For optimum performance, place the refrigerator in an indoor, temperature controlled environment. See "Location Requirements."
	A large amount of warm food has been recently added.	Warm food will cause the refrigerator to run longer until the air cools to the desired temperature.
	The door(s) are opened too frequently or for too long.	Warm air entering the refrigerator causes it to run more. Open the door less often.
	The refrigerator door or freezer drawer is ajar.	Make sure the refrigerator is level. See "Refrigerator Leveling, Door Closing and Alignment." Keep food and containers from blocking the door.
	The refrigerator control is set too cold.	Adjust the refrigerator control to a less cold setting until the refrigerator temperature is as desired.
The lights do not work	The door or drawer gasket is dirty, worn, or cracked.	Clean or change the gasket. Leaks in the door seal will cause the refrigerator to run longer in order to maintain desired temperatures.
	Your refrigerator is equipped with LED lighting which does not need to be replaced.	If there is power to the refrigerator and the lights do not illuminate when a door or drawer is opened, call for service or assistance.
	The dispenser light is set to OFF.	On some models, the dispenser light will operate only when a dispenser paddle is pressed. If you want the dispenser light to stay on continuously, see "Water and Ice Dispensers."
Shelves with under-shelf LEDs do not light up (on some models)	Doors have been open longer than 10 minutes.	Close the doors and drawer to reset, and open to resume lighted task.
	Shelf hooks are not fully engaged in shelf supports.	Check that the rear shelf hooks are completely seated into the slots in the shelf supports.
	Shelf supports, fastened to the back wall of the refrigerator cabinet, are loose.	Check all shelf support screws to ensure they are fully tightened. Tighten all loose screws.
Pantry Temperature Control not lit/unresponsive	Doors have been open longer than 10 minutes.	Close the doors and drawer to reset, and open to resume lighted task.
	The refrigerator is in Cooling Off mode.	Exit Cooling Off mode. See "Using the Control(s)."
	The refrigerator controls' initialization process did not complete successfully.	Unplug the refrigerator, wait 5 seconds. Plug in the refrigerator, and wait 30 seconds before opening any of the refrigerator doors or touching the control panel.

Noise

To listen to normal refrigerator sounds, go to the Product Help/FAQ section of the brand website and search for "normal sounds."

PROBLEM	POSSIBLE CAUSES	SOLUTIONS
The refrigerator seems noisy Below are listed some normal sounds with explanations.	The compressor in your new refrigerator regulates temperature more efficiently while using less energy, and operates quietly. Due to this reduction in operating noise, you may notice unfamiliar noises that are normal.	
Sound of the compressor running longer than expected	High-efficiency compressor and fans	Larger, more efficient refrigerators run longer at lower, more energy efficient speeds.
Pulsating/Whirring	Fans/compressor adjusting to optimize performance during normal compressor operation	This is normal.

TROUBLESHOOTING

PROBLEM	POSSIBLE CAUSES	SOLUTIONS
Popping	Contraction/expansion of inside walls, especially during initial cool-down	This is normal.
Hissing/Dripping	Flow of refrigerant, or flow of oil in the compressor	This is normal.
Vibration	The refrigerator may not be steady	Adjust the leveling screws and lower the leveling foot firmly against the floor. See “Refrigerator Leveling, Door Closing and Alignment.”
Rattling/Banging	Movement of the water lines against the refrigerator cabinet, or of items placed on top of the refrigerator cabinet	Move excess water line away from the refrigerator cabinet or fasten excess tubing to the cabinet. See “Connecting the Water,” or remove items from the top of the refrigerator.
Sizzling	Water dripping on the heater during defrost cycle	This is normal.
Water running/Gurgling	May be heard when ice melts during the defrost cycle and water runs into the drain pan	This is normal.
Buzzing and Clicking	Heard when the water valve opens and closes to dispense water and/or fill the ice maker	If the refrigerator is connected to a water line, this is normal. If the refrigerator is not connected to a water line, turn OFF the ice maker.
Repetitive Clicking	Dual evaporator valve regulating the cooling operation	You may hear rapid repetitive clicking sounds as the unit switches from cooling one compartment to cooling the other. This sound is normal.
Creaking/Cracking/Grinding	May be heard as ice is being ejected from the ice maker mold	This is normal.
Clatter	May be heard when the ice falls into the ice storage bin	This is normal.

Temperature and Moisture

PROBLEM	POSSIBLE CAUSES	SOLUTIONS
Temperature is too warm	The refrigerator has just been installed.	Allow 24 hours following installation for the refrigerator to cool completely.
	Cooling is turned off.	Turn on cooling. See “Using the Control(s).”
	The controls are not set correctly for the surrounding conditions.	Adjust the controls a setting colder. Check the temperature in 24 hours. See “Using the Control(s).”
	The door(s) are opened often or not closed completely.	Allows warm air to enter refrigerator. Minimize door openings and keep doors fully closed.
Temperature is too cold in the refrigerator/ crispers	A large load of food was recently added.	Allow several hours for refrigerator to return to normal temperature, or see “Using the Control(s)” for information about how to speed up the cooling process (on some models).
	The refrigerator air vent(s) are blocked.	If the air vent located in the top, left, rear corner of the refrigerator compartment is blocked by items placed directly in front of it, the refrigerator will get too cold. Move items away from the air vent.
	The controls are not set correctly for the surrounding conditions.	Adjust the controls a setting warmer. Check the temperature in 24 hours. See “Using the Control(s).”
Temperature is too cold in the pantry drawers	The ice storage bin is not in the correct position.	See “Ice Maker and Ice Storage Bin.”
	The control is not set correctly for the items stored in drawer.	Adjust the temperature setting. See “Temperature Controlled Drawer” in the “Refrigerator Features” section.

TROUBLESHOOTING

PROBLEM	POSSIBLE CAUSES	SOLUTIONS
There is interior moisture buildup NOTE: Some moisture buildup is normal.	The room is humid.	A humid environment contributes to moisture buildup.
	The door(s) are opened often or not closed completely.	Allows humid air to enter the refrigerator. Minimize door openings and close doors completely.
	The door is blocked open.	Move food packages away from door.
	A bin or shelf is in the way.	Push bin or shelf back into the correct position.
	Storing liquid in open containers	This adds humidity to the refrigerator interior. Keep all containers tightly covered.
There is frost/ice buildup in the freezer compartment	The drawer is opened often or left open.	Minimize drawer openings and close drawer completely after use.
	Poor door seal	Ensure door seals are making full contact with the refrigerator cabinet to allow for an adequate seal.
	Temperature controls are not set correctly.	See "Using the Control(s)" for recommended temperature settings.

Ice and Water

PROBLEM	POSSIBLE CAUSES	SOLUTIONS
The ice maker is not producing ice or is not producing enough ice.	The refrigerator is not connected to a water supply or the water supply shut-off valve is not turned on.	Connect refrigerator to water supply and turn water shut-off valve to fully open.
	There is a kink in the water source line.	A kink in the line can reduce water flow. Straighten the water source line.
	The ice maker is not turned on.	Make sure the ice maker is on. See the "Ice Maker and Storage Bin" section.
	The refrigerator has just been installed.	Wait 24 hours after ice maker installation for ice production to begin. Wait 3 days for full ice production.
	The refrigerator door is not closed completely.	Close the door firmly. If it does not close completely, see "The doors will not close completely" in this table.
	A large amount of ice was recently removed.	Allow sufficient time for ice maker to produce more ice. See the "Ice Maker and Storage Bin" section for ice production rates.
	An ice cube is jammed in the ice maker.	Remove ice from the ice maker with a plastic utensil.
	A water filter is installed on the refrigerator.	Remove the water filter and operate the ice maker. If ice volume improves, then the filter may be clogged or incorrectly installed. Replace filter or reinstall it correctly.
	A reverse osmosis water filtration system is connected to the cold water supply.	This can decrease water pressure. See the "Water Supply Requirements" section.
	The ice cubes are hollow or small. NOTE: This is an indication of low water pressure.	The water shut-off valve is not fully open.
There is a kink in the water source line.		A kink in the line can reduce water flow. Straighten the water source line.
A water filter is installed on the refrigerator.		Remove filter and operate ice maker. If ice quality improves, then the filter may be clogged or incorrectly installed. Replace filter or reinstall it correctly.
A reverse osmosis water filtration system is connected to the cold water supply.		This can decrease water pressure. See the "Water Supply Requirements" section.
Questions remain regarding water pressure.		Call a licensed, qualified plumber.

TROUBLESHOOTING

PROBLEM	POSSIBLE CAUSES	SOLUTIONS
Off-taste, odor, or gray color in the ice or water	Newly installed refrigerator requires flush of water system.	Flush the water system. See the “Water and Ice Dispensers” section for water system flushing instructions.
	Recently installed or replaced plumbing connections. New plumbing connections can cause discolored or off-flavored ice and water.	Discard ice and wash the ice storage bin. Flush the water system with 3 gal. (12 L) of water. Allow 24 hours for the ice maker to make new ice and discard the first 3 batches of ice produced.
	Using a water supply connection type other than recommended	It is recommended to use copper tubing or Whirlpool® supply line, Part Number 8212547RP. See the “Connect the Water Supply” section.
	The ice has been stored too long.	Discard ice and wash ice storage bin. Allow 24 hours for ice maker to make new ice.
	The water has been stored too long.	Dispense at least 1 qt (1 L) of water per week to maintain a fresh supply.
	Odor from stored food has transferred to the ice.	Use airtight, moisture-proof packaging to store food.
	There are minerals (such as sulfur) in the water.	A water filter may need to be installed to remove the minerals.
	There is a water filter installed on the refrigerator.	Gray or dark discoloration in ice may indicate that the water filtration system needs additional flushing. Flush the water system after installing and before using a new water filter. See the “Water and Ice Dispensers” section for water filter flushing instructions.
The water filter needs to be replaced.	Replace the disposable water filter at least every 6 months or when indicated. See “Water Filtration System.”	
The water and ice dispenser will not operate properly.	The refrigerator is not connected to a water supply or the water supply shut-off valve is not turned on.	Connect the refrigerator to the water supply, and turn the water shut-off valve to fully open.
	There is a kink in the water source line.	A kink in the water line can reduce water flow from the water dispenser and result in hollow or irregular-shaped ice. Straighten the water source line.
	The refrigerator has just been installed.	Flush and fill the water system. See the “Water and Ice Dispensers” section.
	The water pressure to the house is not at or above 35 psi (241 kPa).	The water pressure to the house determines the flow from the dispenser. See the “Water Supply Requirements” section.
	A reverse osmosis water filtration system is connected to the cold water supply.	A reverse osmosis water filtration system can decrease water pressure. See the “Water Supply Requirements” section.
	The water filter may be clogged.	Remove the water filter and operate dispenser. If water flow increases, your filter is clogged and needs to be replaced. See the “Water Filtration System” section.
	The water filter is installed incorrectly.	Remove the water filter and reinstall. See the “Water Filtration System” section.
	The refrigerator door or freezer drawer is not closed completely.	Close the door or drawer firmly. If it does not close completely, see “The doors will not close completely” section.
	The refrigerator doors were recently removed.	Make sure the water dispenser wire/tube assembly has been properly reconnected at the top of the refrigerator door. See “Remove and Replace Refrigerator Doors” section.
	Ice is clogged in the ice storage bin or ice is blocking the ice delivery chute.	Remove the ice clogging the storage bin and delivery chute, using a plastic utensil if necessary. Clean the ice delivery chute and the bottom of the ice storage bin using a warm, damp cloth, then dry both thoroughly. To avoid clogging and to maintain a fresh supply of ice, empty the storage bin and clean both the storage bin and delivery chute every 2 weeks.

TROUBLESHOOTING

PROBLEM	POSSIBLE CAUSES	SOLUTIONS
The ice dispenser jams while dispensing crushed ice	Crushed ice is blocking the ice delivery chute.	Switch from crushed ice to cubed ice to clear the ice dispenser. Then switch back to crushed ice.
Water is leaking or dripping from the dispenser system NOTE: A few drops of water after dispensing is normal.	The glass was not held under the dispenser long enough.	Hold the glass under the dispenser 2 to 3 seconds after releasing the dispenser lever.
Water continues to drip from the dispenser beyond the first few drops.	The refrigerator has just been installed.	Flushing the water system removes the air from the lines which causes the water dispenser to drip. Flush the water system. See “Water and Ice Dispensers.”
	The water filter was recently installed or replaced.	Flushing the water system removes the air from the lines which causes the water dispenser to drip. Flush the water system. See “Water and Ice Dispensers.”
Water is leaking from the back of the refrigerator	The water line connections were not fully tightened.	See “Connecting the Water.”
	Recently removed the doors and did not fully tighten water line connection	See “Remove and Replace Refrigerator Doors.”
Water from the dispenser is warm	Water from the dispenser is chilled to 50°F (10°C).	This is normal.
	The refrigerator has just been installed.	Allow 24 hours after installation for the water supply to cool completely.
	A large amount of water was recently dispensed.	Allow 3 hours for the water supply to cool completely.
	Water has not been recently dispensed.	The first glass of water may not be cool. Discard the first glass of water dispensed.
	The refrigerator is not connected to a cold water pipe.	Make sure the refrigerator is connected to a cold water pipe. See “Water Supply Requirements.”

Doors



To view an animation showing how to adjust and align the doors, refer to the Product Help/FAQ section of the brand website and search for “door closing and door alignment.”

PROBLEM	POSSIBLE CAUSES	SOLUTIONS
The doors will not close completely.	The door is blocked open.	Move food packages away from door.
	A bin or shelf is in the way.	Push bin or shelf back into the correct position.
	Recently installed	Remove all packaging materials.

TROUBLESHOOTING

PROBLEM	POSSIBLE CAUSES	SOLUTIONS
The doors are difficult to open.	The door gaskets are dirty or sticky.	Clean gaskets and contact surfaces with mild soap and warm water. Rinse and dry with soft cloth.
The doors appear to be uneven.	The doors need to be aligned or the refrigerator needs to be leveled.	See the “Refrigerator Leveling and Door Closing” section.
The refrigerator is unsteady or it rolls forward when opening and closing doors.	The refrigerator brake feet are not snug against the floor.	Remove the base grille. Turn both brake feet (one on each side) clockwise, the same amount, until they are snug against the floor. See “Refrigerator Leveling, Door Closing and Alignment.”

PERFORMANCE DATA SHEETS

Water Filtration System Model P9WB2L/P9RFB2L Capacity 200 Gallons (757 Liters)



System tested and certified by NSF International against NSF/ANSI Standard 42, Standard 53, Standard 401, and CSA B483.1 for the reduction of contaminants specified on the Performance Data Sheet.

This system has been tested according to NSF/ANSI Standards 42, 53, 401, and CSA B483.1 for the reduction of the substances listed below. The concentration of the indicated substances in water entering the system was reduced to a concentration less than or equal to the permissible limit for water leaving the system, as specified in NSF/ANSI Standards 42, 53, 401, and CSA B483.1.

Substance Reduction Aesthetic Effects	Influent Challenge Concentration	Maximum Permissible Product Water Concentration	Average % Reduction
Chlorine Taste/Odor	2.0 mg/L ± 10%	50% reduction	97.0%
Particulate Class I*	At least 10,000 particles/mL	85% reduction	>99.9%
Contaminant Reduction	Influent Challenge Concentration	Maximum Permissible Product Water Concentration	Average % Reduction
Lead: @ pH 6.5 / @ pH 8.5	0.15 mg/L ± 10%	0.010 mg/L	>99.3%/98.6%
Benzene	0.015 mg/L ± 10%	0.005 mg/L	93.8%
p-Dichlorobenzene	0.225 mg/L ± 10%	0.075 mg/L	99.8%
Carbofuran	0.08 mg/L ± 10%	0.040 mg/L	81.9%
Toxaphene	0.015 ± 10%	0.003 mg/L	>95%
Atrazine	0.009 mg/L ± 10%	0.003 mg/L	87.0%
Asbestos	10 ⁷ to 10 ⁸ fibers/L††	99%	>99%
Live Cysts†	50,000/L min.	99.95%	>99.99%
Turbidity	11 NTU ± 10%	0.5 NTU	96.9%
Lindane	0.002 ± 10%	0.0002 mg/L	>99.2%
Tetrachloroethylene	0.015 mg/L ± 10%	0.005 mg/L	96.6%
O-Dichlorobenzene	1.8 mg/L ± 10%	0.60 mg/L	92.3%
Ethylbenzene	2.1 mg/L ± 10%	0.70 mg/L	86.9%
1,2,4-Trichlorobenzene	0.210 mg/L ± 10%	0.07 mg/L	>99.8%
2,4 - D	0.210 mg/L ± 10%	0.07 mg/L	88.5%
Styrene	2.0 mg/L ± 10%	0.1 mg/L	99.6%
Toluene	3.0 mg/L ± 10%	1.0 mg/L	93.5%
Endrin	0.006 mg/L ± 10%	0.002 mg/L	81.7%
Atenolol	200 ± 20%	30 ng/L	95.7%
Trimethoprim	140 ± 20%	20 ng/L	96.1%
Linuron	140 ± 20%	20 ng/L	96.3%
Estrone	140 ± 20%	20 ng/L	95.3%
Nonylphenol	1400 ± 20%	200 ng/L	95.5%

Test Parameters: pH = 7.5 ± 0.5 unless otherwise noted. Flow = 0.75 gpm (2.84 Lpm). Pressure = 60 psig (413.7 kPa). Temp. = 68°F to 71.6°F (20°C to 22°C). Rated service capacity = 200 gallons (757 liters).

The compounds certified under NSF 401 have been deemed as “emerging compounds/incidental contaminants.” Emerging compounds/incidental contaminants are those compounds that have been detected in drinking water supplies at trace levels. While occurring at only trace levels, these compounds can affect the public acceptance/perception of drinking water quality.

- It is important that operational, maintenance, and filter replacement requirements be carried out for the product to perform as advertised. Property damage can occur if all instructions are not followed.
- The disposable cartridge must be changed at least every 6 months.
- Use replacement filter P9RFB2L, part #EDR2RXD1/EDR2RXD1B. 2015 suggested retail price of \$49.99 U.S.A./\$49.99 Canada. Prices are subject to change without notice.
- The filter monitor system measures the amount of water that passes through the filter and alerts you when it is time to replace the filter. Refer to the “Using the Controls” or “Water Filtration System” section (in the User Instructions or User Guide) to learn how to check the water filter status.
- After changing the water filter, flush the water system. See “Water and Ice Dispensers” or “Water Dispenser” in the User Instructions or User Guide.
- These contaminants are not necessarily in your water supply. While testing was performed under standard laboratory conditions, actual performance may vary.
- The product is for cold water use only.
- The water system must be installed in compliance with state and local laws and regulations.
- Do not use with water that is microbiologically unsafe or of unknown quality without adequate disinfection before or after the system. Systems certified for cyst reduction may be used on disinfected waters that may contain filterable cysts. EPA Est. No. 082047-TWN-001
- Refer to the “Warranty” section (in the User Instructions or User Guide) for the Manufacturer’s limited warranty, name, and telephone number.

Application Guidelines/Water Supply Parameters

Water Supply	Potable City or Well
Water Pressure	35 - 120 psi (241 - 827 kPa)
Water Temperature	33° - 100°F (1° - 38°C)
Service Flow Rate	0.75 gpm (2.84 L/min.) @ 60 psi (413.7 kPa)

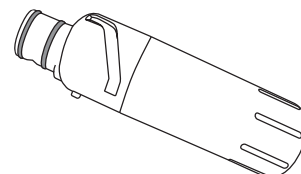

*Class I particle size: >0.5 to <1 µm

†Based on the use of *Cryptosporidium parvum* oocysts

††Fibers greater than 10 µm in length

®NSF is a registered trademark of NSF International.

WHIRLPOOL® REFRIGERATION LIMITED WARRANTY

ATTACH YOUR RECEIPT HERE. PROOF OF PURCHASE IS REQUIRED TO OBTAIN WARRANTY SERVICE.

Please have the following information available when you call the Customer eXperience Center:

- Name, address, and telephone number
- Model number and serial number
- A clear, detailed description of the problem
- Proof of purchase, including dealer or retailer name and address

IF YOU NEED SERVICE:

1. Before contacting us to arrange service, please determine whether your product requires repair. Some questions can be addressed without service. Please take a few minutes to review the Troubleshooting section of the Use and Care Guide or visit producthelp.whirlpool.com.
2. All warranty service is provided exclusively by our authorized Whirlpool Service Providers. In the U.S. and Canada, direct all requests for warranty service to:

Whirlpool Customer eXperience Center

In the U.S.A., call 1-800-253-1301. In Canada, call 1-800-807-6777.

If outside the 50 United States or Canada, contact your authorized Whirlpool dealer to determine whether another warranty applies.

FIVE YEAR LIMITED WARRANTY

WHAT IS COVERED

ONE YEAR LIMITED WARRANTY

For one year from the date of purchase, when this major appliance is installed, operated, and maintained according to instructions attached to or furnished with the product, Whirlpool Corporation or Whirlpool Canada LP (hereafter "Whirlpool") will pay for factory specified replacement parts and repair labor to correct defects in materials or workmanship that existed when this major appliance was purchased or, at its sole discretion, replace the product. In the event of product replacement, your appliance will be warranted for the remaining term of the original unit's warranty period.

SECOND THROUGH FIFTH YEAR LIMITED WARRANTY ON CAVITY LINER AND SEALED REFRIGERATION SYSTEM

In the second through fifth years from the date of purchase, when this major appliance is installed, operated, and maintained according to the instructions attached to or furnished with the product, Whirlpool brand will pay for factory specified replacement parts and repair labor for the following components to correct non-cosmetic defects in materials and workmanship in this part that prevent function of the refrigerator and that existed when this major appliance was purchased:

- Refrigerator/freezer cavity liner if the part cracks due to defective materials or workmanship
- Sealed Refrigeration system (includes compressor, evaporator, condenser, dryer, and connecting tubing)

YOUR SOLE AND EXCLUSIVE REMEDY UNDER THIS LIMITED WARRANTY SHALL BE PRODUCT REPAIR AS PROVIDED HEREIN. Service must be provided by a Whirlpool designated service company. This limited warranty is valid only in the United States or Canada and applies only when the major appliance is used in the country in which it was purchased. This limited warranty is effective from the date of original consumer purchase. Proof of original purchase date is required to obtain service under this limited warranty.

WHAT IS NOT COVERED

1. Commercial, non-residential, or multiple-family use, or use inconsistent with published user, operator, or installation instructions.
2. In-home instruction on how to use your product.
3. Service to correct improper product maintenance or installation, installation not in accordance with electrical or plumbing codes, or correction of household electrical or plumbing (e.g., house wiring, fuses, or water inlet hoses).
4. Consumable parts (e.g., light bulbs, batteries, air or water filters, preservation solutions, etc.).
5. Defects or damage caused by the use of non-genuine Whirlpool parts or accessories.
6. Damage from accident, misuse, abuse, fire, floods, acts of God, or use with products not approved by Whirlpool.
7. Repairs to parts or systems to correct product damage or defects caused by unauthorized service, alteration, or modification of the appliance.
8. Cosmetic damage, including scratches, dents, chips, and other damage to the appliance finishes, unless such damage results from defects in materials and workmanship and is reported to Whirlpool within 30 days.
9. Discoloration, rust, or oxidation of surfaces resulting from caustic or corrosive environments including, but not limited to, high salt concentrations, high moisture or humidity, or exposure to chemicals.
10. Food or medicine loss due to product failure.
11. Pickup or delivery. This product is intended for in-home repair.
12. Travel or transportation expenses for service in remote locations where an authorized Whirlpool servicer is not available.
13. Removal or reinstallation of inaccessible appliances or built-in fixtures (e.g., trim, decorative panels, flooring, cabinetry, islands, countertops, drywall, etc.) that interfere with servicing, removal, or replacement of the product.
14. Service or parts for appliances with original model/serial numbers removed, altered, or not easily determined.

The cost of repair or replacement under these excluded circumstances shall be borne by the customer.

DISCLAIMER OF IMPLIED WARRANTIES

IMPLIED WARRANTIES, INCLUDING ANY IMPLIED WARRANTY OF MERCHANTABILITY OR IMPLIED WARRANTY OF FITNESS FOR A PARTICULAR PURPOSE, ARE LIMITED TO ONE YEAR OR THE SHORTEST PERIOD ALLOWED BY LAW. Some states and provinces do not allow limitations on the duration of implied warranties of merchantability or fitness, so this limitation may not apply to you. This warranty gives you specific legal rights, and you also may have other rights that vary from state to state or province to province.

DISCLAIMER OF REPRESENTATIONS OUTSIDE OF WARRANTY

Whirlpool makes no representations about the quality, durability, or need for service or repair of this major appliance other than the representations contained in this warranty. If you want a longer or more comprehensive warranty than the limited warranty that comes with this major appliance, you should ask Whirlpool or your retailer about buying an extended warranty.

LIMITATION OF REMEDIES: EXCLUSION OF INCIDENTAL AND CONSEQUENTIAL DAMAGES

YOUR SOLE AND EXCLUSIVE REMEDY UNDER THIS LIMITED WARRANTY SHALL BE PRODUCT REPAIR AS PROVIDED HEREIN. WHIRLPOOL SHALL NOT BE LIABLE FOR INCIDENTAL OR CONSEQUENTIAL DAMAGES. Some states and provinces do not allow the exclusion or limitation of incidental or consequential damages, so these limitations and exclusions may not apply to you. This warranty gives you specific legal rights, and you also may have other rights that vary from state to state or province to province.

NOTES

AT YOUR SERVICE

Please refer to the warranty page for additional instructions on how to obtain service for your product.

WE CAN HELP WITH YOUR QUESTIONS

You will need the model and serial number, located on the inside wall of the refrigerator compartment. For future reference, record the model and serial number here.

Serial Number _____ Model Number _____

Country	Call	or Visit Us Online At	Write
U.S.A.	1-800-253-1301	www.whirlpool.com	Whirlpool Brand Home Appliances Customer eXperience Center 553 Benson Road Benton Harbor, MI 49022-2692
Canada	1-800-807-6777	www.whirlpool.ca	Whirlpool Brand Home Appliances Customer eXperience Center 200 – 6750 Century Ave. Mississauga, Ontario L5N 0B7



À VOTRE SERVICE

Consulte la página de la garantía para instrucciones adicionales sobre cómo obtener servicio para su producto.

NOUS POUVONS RÉPONDRE À VOS QUESTIONS

Vous aurez besoin des numéros de modèle et de série situés sur la paroi interne du compartiment de réfrigération.

Pour référence ultérieure, inscrire les numéros de modèle et de série ci-dessous.

Numéro de série _____ Numéro de modèle _____

Pays	Composez le	Ou rejoignez-nous en ligne à l'adresse	Écrivez-nous à l'adr
Canada	1-800-807-6777	www.whirlpool.ca	Whirlpool Brand Home Appliances Customer eXperience Center 200 – 6750 Century Ave. Mississauga, Ontario L5N 0B7